

# **INVITATION FOR BIDS**



## **FOR CONSTRUCTING**

# **ROSELAND PAVEMENT MAINTENANCE**

CONTRACT NUMBER

**C02113**

ISSUED BY

**CAPITAL PROJECTS ENGINEERING DIVISION**

**CITY OF SANTA ROSA, CALIFORNIA**

**2019**

ATTENTION  
Prebid Conference  
See Page 1



STATE OF CALIFORNIA

INVITATION FOR BIDS

CONTAINING:

NOTICE TO BIDDERS

SPECIAL PROVISIONS

BID FORMS

CONTRACT

FOR

**ROSELAND PAVEMENT MAINTENANCE**

**Contract No. C02113**

# ROSELAND PAVEMENT MAINTENANCE

## TABLE OF CONTENTS

### NOTICE TO BIDDERS

NOTICE TO BIDDERS.....	1
------------------------	---

### SPECIAL PROVISIONS

#### GENERAL SPECIFICATIONS

1 General.....	4
2 Bidding .....	5
3 Contract Award and Execution.....	7
4 Scope of Work .....	11
5 Control of Work .....	12
6 Control of Materials.....	16
7 Legal Relations and Responsibility to the Public.....	19
8 Prosecution and Progress.....	23
9 Measurement and Payment.....	24

#### TECHNICAL SPECIFICATIONS .....28

Section 12	Temporary Traffic Control .....	29
Section 13	Water Pollution Control.....	34
Section 14	Environmental Stewardship .....	37
Section 15	Existing Facilities .....	38
Section 19	Earthwork .....	43
Section 26	Aggregate Base.....	46
Section 39	Hot Mix Asphalt .....	47
Section 56	Signs .....	58
Section 73	Concrete Curbs and Sidewalks.....	59
Section 84	Traffic Stripes and Pavement Markings .....	63
Section 85	Pavement Markers.....	64
Section 121	Notification.....	65
Section 124	Material Recycling .....	66

### BID FORMS

Contract Bid .....	67
Unit Price Schedule.....	68
List of Subcontractors.....	70
List of Previous Similar Jobs .....	71
Noncollusion Declaration.....	72
Bid Bond Affidavit and Bidder's Signature .....	73

### CONTRACT

Contract .....	74
----------------	----

CITY OF SANTA ROSA  
STATE OF CALIFORNIA

**NOTICE TO BIDDERS**

➤	For technical questions regarding this project, contact Danny Chen at (707) 543-3911.
➤	For direct access to plans, specifications and planholders' lists, go to <a href="http://www.srcity.org/bids">www.srcity.org/bids</a> and click on <u>Bid/Proposal Opportunities</u> or call (707) 543-3800.
➤	For direct access to bid results, go to <a href="http://www.srcity.org/bids">www.srcity.org/bids</a> . Under Link to Capital Projects, click on <u>Capital Projects Contracts</u> or call (707) 543-3835.

**- IMPORTANT -**

**Bid Acceptance Deadline**

Sealed bids will be accepted at the Transportation and Public Works Department, 69 Stony Circle, Santa Rosa, California 95401 until 2:00 p.m., May 1, 2019, for Roseland Pavement Maintenance, Contract No. C02113. (Engineer's Estimate: \$973,050.00.)

**Bids tendered after this deadline will not be accepted.** The official time clock for accepting bids will be an electric date and time stamping clock, located in the Transportation and Public Works Department, 69 Stony Circle, Santa Rosa, California. In order to be accepted, bids must be received prior to 2:00 p.m. Therefore, a bid stamped in at 1:59 p.m. will be accepted, but one delivered at or after 2:00 p.m. is late and will not be accepted.

**Pre-Bid Meeting**

Prospective bidders, subcontractors, and material suppliers are invited to attend a pre-bid meeting scheduled to be held at 10:00 a.m., April 24, 2019, in the Transportation and Public Works Department located at 69 Stony Circle, Santa Rosa, California.

**Subcontractor Information; Department of Industrial Relations Registration**

Bidders shall provide the names, business addresses and license numbers of all subcontractors listed on bidder's List of Subcontractors. No contractor or subcontractor may be listed on a bid for this public works project unless registered with the Department of Industrial Relations (DIR) pursuant to Labor Code section 1725.5. No contractor or subcontractor may be awarded a contract for this public works project unless registered with the DIR pursuant to Labor Code section 1725.5. This public works project is subject to compliance monitoring and enforcement by the DIR.

**CITY OF SANTA ROSA  
ESTIMATED QUANTITIES  
C02113 - ROSELAND PAVEMENT MAINTENANCE**

Item No.	Description	Quantity	Units
1	TRAFFIC CONTROL	1	LS
2	WATER POLLUTION CONTROL	1	LS
3	LOWER EXISTING FACILITIES	17	EA
4	ADJUST EXISTING MANHOLE FRAME AND COVER TO GRADE	6	EA
5	ADJUST EXISTING WATER VALVE BOX, MAINLINE CLEANOUT, AND MONUMENT COVER TO GRADE	11	EA
6	UTILITY CLEARANCES	1	LS
7	ROADWAY EXCAVATION (F)	2450	CY
8	SOIL STABILIZATION FABRIC	7350	SY
9	SHOULDER BACKING	25	TON
10	ASPHALT CONCRETE SURFACE	1450	TON
11	ASPHALT CONCRETE BASE	1950	TON
12	CONFORM GRIND	125	LF
13	DRIVEWAY CONFORM (0.25')	300	SY
14	REMOVE AND REPLACE SIGN AND POST	12	EA
15	CURB AND GUTTER	130	LF
16	SIDEWALK	100	SF
17	CURB RAMP	800	SF
18	PAVEMENT MARKINGS, 12" THERMOPLASTIC CROSSWALK AND LIMIT LINES	175	SF
19	PAVEMENT MARKERS, RETRO-REFLECTIVE AND NON-REFLECTIVE	30	EA

The foregoing quantities are approximate only, being given as a basis for the comparison of bids, and the City of Santa Rosa does not expressly or by implication, agree that the actual amount of work will correspond therewith, but reserves the right to increase or decrease the amount of any class or portion of the work, as may be deemed necessary or expedient by the Engineer.

Bids shall be made in accordance with the prevailing hourly rate of per diem wages for this locality and project as determined by the Director of the DIR pursuant to Labor Code sections 1770 *et seq.*

Contractor shall be responsible for compliance with the Immigration Reform Control Act of 1986.

If the project requires the employment of workers in any apprenticeable craft or trade, once awarded, Contractor and subcontractors must apply to the Joint Apprenticeship Council unless already covered by local apprentice standards (see Labor Code section 1777.5).

All bids are to be compared on the basis of the Engineer's estimate of the quantities of work to be performed. No bid will be awarded to a contractor who is not licensed in accordance with the provisions of Chapter 9 of Division 3 of the Business and Professions Code. Contractor must hold a Class A license for this project.

Project plans, bid and contract forms for C02113 Roseland Pavement Maintenance may be obtained through PlanetBids at [www.srcity.org/bids](http://www.srcity.org/bids). These documents can no longer be obtained at the Transportation and Public Works Department.

No bid will be accepted unless it is made on the contract bid forms furnished by the Transportation and Public Works Department through PlanetBids. The original of the completed bid forms bearing original signatures must be submitted. A bid will not be accepted unless the bidder registers as a vendor through PlanetBids at [www.srcity.org/bids](http://www.srcity.org/bids), downloads documents/attachments, and is added to the prospective bidders list for this project. If there is an addendum, bidders must log into PlanetBids and acknowledge the addendum to be eligible for bidding.

The successful bidder will be required to hold a current City of Santa Rosa business tax certificate issued pursuant to Chapter 6.04 of the Santa Rosa City Code before commencing work on this project. For information regarding the business tax, contact Revenue and Collections at (707) 543-3170.

For any moneys earned by Contractor and withheld by the City of Santa Rosa to ensure the performance of the Contract, Contractor may, at its request and expense, substitute securities equivalent to the amount withheld in the form and manner and subject to the conditions provided in Section 22300 of the California Public Contract Code.

The City of Santa Rosa reserves the right to reject any or all bids and the right to waive minor irregularities or informalities in any bid or bonds.



DAVID MONTAGUE  
Supervising Engineer

4/3/2019

Date

# **SPECIAL PROVISIONS**

## **General Specifications**

### **CITY OF SANTA ROSA, CALIFORNIA ROSELAND PAVEMENT MAINTENANCE**

#### **1 GENERAL**

The work described herein shall be done in accordance with the "Contract Documents," which are the:

1. Special Provisions
2. City of Santa Rosa Design and Construction Standards (City Standards)
3. City of Santa Rosa Construction Specifications for Public Improvements (City Specifications)
4. State of California Department of Transportation Standard Specifications 2010 (Standard Specifications), and
5. State of California Department of Transportation Standard Plans 2010 (Standard Plans).

In the event of a conflict in any of these documents, the order of precedence shall be determined by Section 5-1.02 of these Special Provisions.

Whenever the Standard Specifications use the terms State of California, Department of Transportation, Director, Engineer, or Laboratory, the following terms shall be substituted therefor, and any reference to any of the foregoing terms shall be understood and interpreted to mean and refer to such substituted terms as follows:

For State of California - the City of Santa Rosa;

For Department - the City of Santa Rosa Department of Transportation and Public Works or the City of Santa Rosa Water Department;

For Director - the City Engineer of the City of Santa Rosa;

For Engineer - the City Engineer of the City of Santa Rosa or the City Engineer's authorized agents;

For Laboratory – Materials Engineering of the City of Santa Rosa Transportation and Public Works Department, or such other laboratory as may be authorized by the City.

Unless otherwise provided, whenever in these Special Provisions attention is directed to specific provisions in the Standard Specifications, such direction shall not be interpreted as excluding other applicable provisions of the Standard Specifications.

Unless otherwise provided, when sections and subsections of the Standard Specifications are used in these Special Provisions, such use is not exclusive and shall not be interpreted as excluding other applicable provisions of said sections and subsections, but is only intended to add to or modify such sections or subsections.

Unless otherwise provided, full compensation for compliance with these Special Provisions is included in the contract price and no additional allowance will be made to Contractor therefor. The Standard Specifications are hereby modified to delete any reference or incorporation of provisions providing for or requiring arbitration of any and all claims and disputes arising under this contract.

## 2 BIDDING

**2-1.06 Bid Documents:** Prospective bidders will be furnished with an Invitation for Bids which will state the location and description of the contemplated public works project and will show the approximate estimate of the various quantities and kinds of work to be performed and materials to be furnished with a schedule of items for which unit prices are requested.

**2-1.07 Approximate Estimate:** The quantities given in the Contract Documents are approximate only, being given as a basis for the comparison of bids, and the City does not, expressly or by implication, agree that the actual amount of work will correspond therewith, but reserves the right to increase or decrease the amount of any class or part of the work or to omit parts of the work, as may be deemed necessary or advisable by the Engineer.

**2-1.31 Examination of Project Plans, Specifications, City Standards, Invitation for Bids and Work Site:** Prior to submitting a bid, the bidder shall carefully examine the Project Plans, Invitation for Bids, City Standards and the proposed work site. If any person contemplating submitting a bid for this public works project is in doubt as to the meaning of any part of the Contract Documents, or finds discrepancies in or omissions from the Contract Documents, he or she may submit a written request for interpretation or correction to the Engineer. The written request must be received by the Engineer a minimum of 96 hours prior to bid opening. Any interpretation or correction of the Contract Documents prior to bid opening will be made only by written addendum issued by the City. A copy of such addendum will be mailed or faxed to each Planholder. The City will not be bound by any other explanations or interpretations of the Contract Documents.

**2-1.33 Bid Document Completion:** Any references to Opt Out of Payment Adjustments for Price Index Fluctuations in the Standard Specifications are deleted in their entirety.

**2-1.33A Bid Forms:** All bids shall be made on bid forms obtained from PlanetBids at [www.srcity.org/bids](http://www.srcity.org/bids). The bidder shall submit its bid on the original bid forms furnished by the City. Bids submitted on forms other than the forms furnished to the bidder by the City will not be considered.

The bid forms to be submitted at the time of and with the bid are:

1. Unit Price Schedule
2. List of Subcontractors
3. List of Previous Similar Jobs
4. Noncollusion Declaration
5. Bid Guaranty Information and Bidder's Information and Signature
6. Bid Guaranty (Bid Bond or alternate security)

All bids shall give the proposed prices and must bear the original signature of the bidder. Bidders shall fill in all blanks on the bid forms where required. A bid will not be accepted unless the bidder registers as a vendor through PlanetBids at [www.srcity.org/bids](http://www.srcity.org/bids), downloads documents/attachments, and is added to the prospective bidders list for this project. If there is an addendum, bidders must log into PlanetBids and acknowledge the addendum to be eligible for bidding.

**2-1.33B Registration with DIR:** No contractor or subcontractor may be listed on a bid for this public works project unless registered with the Department of Industrial Relations (DIR) pursuant to Labor Code section 1725.5. No contractor or subcontractor may be awarded a contract for this public works project unless registered with the DIR pursuant to Labor Code section 1725.5. This public works project is subject to compliance monitoring and enforcement by the DIR.



**2-1.33C Subcontractors:** The Subletting and Subcontracting Fair Practices Act, Public Contract Code sections 4100-4113, inclusive (the "Act") shall apply to all subcontracts in excess of one-half of one percent of the total amount of a bid. The Act requires subcontractors, if used for such work, to be listed in the contractor's bid and prohibits the substitution of subcontractors, except as authorized by the Act. Each bidder shall, with respect to the work of any subcontractor in excess of one-half of one percent of the total amount of the bid, include as part of the bid on the bid form provided:

1. The name, business address and DIR registration number of each subcontractor who will perform work or labor or render services to the Contractor in or about the construction of the work or improvement, or a subcontractor licensed by the State of California who, under subcontract to the Contractor, specially fabricates and installs a portion of the work or improvement according to detailed drawings contained in the Project Plans or other Contract Documents in an amount in excess of one-half of one percent of the Contractor's total bid; and
2. The portion of the work that will be done by each subcontractor. Only one subcontractor shall be listed for each portion.

The purchase of sand, gravel, crushed rock, batched concrete, aggregate, ready-mixed concrete, and/or any other materials produced and furnished by established and recognized commercial plants, together with the delivery of such materials to the work site by the source of the materials or by recognized commercial hauling companies, is not considered as subcontracting under this section.

**2-1.33E Rejection of Bids Containing Alterations, Erasures or Irregularities:** Bids may be rejected if they show any alterations of forms, additions not called for, conditional bids, incomplete bids, erasures or irregularities of any kind.

**2-1.34 Bid Guaranty:** All bids shall be presented under sealed cover and shall be accompanied by cash, cashier's or certified check, or by a bidder's bond made payable to the City of Santa Rosa and executed as surety by a corporate surety authorized and admitted to transact a surety business in the State of California in an amount equal to ten percent of the amount of the bid. No bid shall be considered unless such cash, cashiers or certified check, or bidder's bond is enclosed with the bid. Any bidder's bond shall contain provisions for forfeiture consistent with California Public Contract Code section 20172.

**2-1.40 Withdrawal of Bid:** A bid may be withdrawn prior to, but not after, the hour fixed in the public notice for the opening of bids, provided that a written request to withdraw the bid, executed by the bidder or the bidder's authorized representative, is filed with the Engineer before this deadline. The withdrawal of a bid shall not prejudice the right of a bidder to submit a new bid.

**2-1.43 Public Opening of Bids:** Bids will be opened and read publicly at the time and place indicated in the Notice to Bidders. Bidders or their authorized agents are invited to be present.

**2-1.46 Disqualification of Bidders:** Serial bids from the same bidder will not be accepted. This section shall not be interpreted to mean that the same contractor may not be the contractor in one bid and listed as a subcontractor in another bid, provided that no collusion exists.

**2-1.48 Competency of Bidders:** No bid will be accepted from or contract awarded to a contractor that is not licensed in accordance with the law, that does not hold a license qualifying it to perform work under this contract, to whom a bid form has not been issued by the Engineer, or that has not successfully completed projects of similar character, scope and cost to the proposed project. Bidders will be required to provide a list of previous similar jobs with their bids.

### 3 CONTRACT AWARD AND EXECUTION

**3-1.04 Contract Award:** The City reserves the right to reject any or all bids. Bids are required for the entire work described herein. All bids will be compared with the Engineer's estimate of the quantities of work to be completed. Contract award, if any, will be made to the lowest responsible bidder within sixty days from the date bids are opened.

**3-1.05 Contract Bonds:** Within ten days after receipt of the Notice of Award, the successful bidder shall provide the following bonds to the City:

- a. **Performance Bond:** A performance bond to guarantee the faithful performance of the terms and conditions of the Contract by Contractor, which shall be executed in a sum of not less than one-half of the Contract price;
- b. **Labor and Materials Bond:** A labor and materials bond (payment bond) in accordance with Part 6 of Division 4, sections 8000 *et seq.* of the California Civil Code, to guarantee against any and all claims of subcontractors or other third parties furnishing labor, materials, or supplies for the Contract, which shall be executed in a sum of 100% of the Contract price; and
- c. **Material Guaranty Bond:** A material guaranty bond (warranty bond) to serve as surety for the guarantee requirements outlined in Section 6-3.01B, which shall be executed in a sum of not less than one-half of the Contract price.

The bond(s) shall be provided in a form acceptable to the City and issued by a corporate surety in good financial standing and authorized and admitted to transact a surety business in the state of California for the purposes and in the amount(s) stated above.

Whenever the financial or legal status of any surety on any such bond(s) is/are unacceptable to the City, it may make a demand to Contractor for further bond(s) or additional surety, not exceeding the sums originally required. Thereafter, no payment shall be made upon the Contract to Contractor or any assignees of Contractor until such bond(s) or additional surety has/have been provided to the City.

**3-1.07 Indemnification and Insurance:** Indemnification: Contractor shall defend, hold harmless and indemnify City, its officers, agents and employees, and each and every one of them, from and against any and all actions, damages, costs, liabilities, claims, demands, losses, judgments, penalties, costs and expenses of every type and description, including, but not limited to, any fees and/or costs reasonably incurred by City's staff attorneys or outside attorneys and any fees and expenses incurred in enforcing this provision (hereafter collectively referred to as "Liabilities"), including but not limited to Liabilities arising from personal injury or death; damage to personal, real or intellectual property or the environment; contractual or other economic damages, or regulatory penalties, arising out of or in any way connected with the performance of or the failure to perform the Contract by Contractor, any subcontractor or agent, anyone directly or indirectly employed by any of them or anyone for whose acts any of them may be liable, whether or not such Liabilities are caused in part by a party indemnified hereunder, or such Liabilities are litigated, settled or reduced to judgment; provided, that the foregoing indemnity does not apply to liability for any damage or expense for death or bodily injury to persons or damage to property to the extent arising from (i) the sole negligence, or willful misconduct of, or defects in design furnished by City, its agents, servants, or independent contractors who are directly responsible to City (excluding Contractor), or (ii) the active negligence of City.

The existence of any of the insurance policies or coverages described in this Contract shall not affect or limit any of City's rights hereunder, nor shall the limits of such insurance limit Contractor's liability to the City hereunder. The provisions of this section shall survive any expiration or termination of the Contract.

**Insurance:** Contractor shall maintain in full force and effect all of the insurance coverage described in and in accordance with the insurance requirements set forth below. Maintenance of such insurance coverage during the entire performance of the Contract is a material element of the Contract. Failure by Contractor to (i) maintain or renew coverage, (ii) provide notice of any changes, modifications, or reductions in coverage, or (iii) provide evidence of renewal, if necessary, may be deemed a material breach of the Contract by Contractor, whereas the City shall be entitled to all rights and remedies at law or in equity. Notwithstanding the foregoing, any failure by Contractor to maintain required insurance coverage shall not excuse or alleviate Contractor from any of its other duties or obligations under the Contract. In the event Contractor retains or utilizes any subcontractors or sub-consultants in performance of the work, Contractor shall assure that any such subcontractor has first obtained, and shall maintain, all of the insurance coverage requirements herein set forth below.

**Insurance Requirements:**

**A. Insurance Policies:** Contractor shall maintain and keep in full force and effect, the following policies of insurance with minimum coverage as indicated below and issued by insurers with an AM Best rating of no less than A:VI or a rating otherwise acceptable to the City.

Insurance	Minimum Coverage Limits	Additional Coverage Requirements
1. Commercial general liability	\$5 million per occurrence \$5 million aggregate	Coverage must be at least as broad as ISO CG 00 01 and must include products liability and completed operations coverage which shall continue for a period of three years after acceptance of the work by the City. If insurance applies separately to a project/location, aggregate may be equal to per occurrence amount. Coverage may be met by a combination of primary and umbrella or excess insurance but umbrella and excess shall provide coverage at least as broad as specified for underlying coverage. Completed Operations Coverage can be provided in the form of an endorsement to Contractor's insurance (at least as broad as ISO Form CG 20 37 04 13. See endorsements below for other Additional Insured Requirements. Coverage shall not exclude subsidence.
2. Business auto coverage	\$3 million	Coverage at least as broad as ISO Form Number CA 00 01 covering any auto (Code 1). Insurance shall cover owned, non-owned and hired autos.

3.	Workers' compensation and Employer's Liability	\$1 million	As required by the State of California, with Statutory Limits and Employer's Liability Insurance with limit of no less than \$1 million per accident for bodily injury or disease. The Workers' Compensation policy shall be endorsed with a waiver of subrogation in favor of the City for all work performed by Contractor, its employees, agents and subcontractors.
4.	Contractor's pollution legal liability and/or asbestos legal liability and/or errors and omission	\$1 million per occurrence or claim \$2 million aggregate	If the work involves lead-based paint or asbestos identification/remediation, the pollution liability policy must not contain lead-based paint or asbestos exclusions. If the work involves mold identification, the pollution liability policy must not contain a mold exclusion and a definition of "Pollution" in said policy shall include microbial matter including mold.

**B. Endorsements:**

1. All policies shall provide or be endorsed to provide that coverage shall not be canceled by either party, except after prior written notice has been provided to the City in accordance with the policy provisions.
2. Liability policies shall provide or be endorsed to provide the following:
  - a. For any claims related to this Contract, Contractor's insurance coverage shall be primary and any insurance or self-insurance maintained by City shall be in excess of Contractor's insurance and shall not contribute with it. Endorsements at least as broad as 20 01 04 13 or evidence of policy language will be required in non ISO CGL policies.
  - b. **The City of Santa Rosa, its officers, agents and employees are to be covered as additional insureds on the CGL policy.** Additional Insured Endorsements at least as broad as 20 10 04 13 or 20 38 04 13 are required.

**C. Verification of Coverage and Certificates of Insurance:** Contractor shall furnish City with original certificates and endorsements effecting coverage required above. Certificates and endorsements shall make reference to policy numbers. All certificates and endorsements are to be received and approved by the City before work commences and must be in effect for the duration of the Contract. The City reserves the right to require complete copies of all required policies and endorsements during the duration of the Contract and for a period of three years following City's acceptance of the work.

**D. Other Insurance Provisions:**

1. No policy required by this Contract shall prohibit Contractor from waiving any right of recovery prior to loss. Contractor hereby waives such right with regard to the indemnitees.
2. All insurance coverage amounts provided by Contractor and available or applicable to this Contract are intended to apply to the full extent of the policies. Nothing contained in this Contract limits the application of such insurance coverage. Coverage for an additional insured shall NOT be limited to the insured's vicarious liability. Defense costs must be paid in addition to coverage amounts.
3. Self-insured retentions above \$10,000 must be approved by the City. At the City's option, Contractor may be required to provide financial guarantees.

4. City reserves the right to modify these insurance requirements, including limits, based on the nature of the risk, prior experience, insurer, coverage, or other special circumstances.

**3-1.18 Contract Execution:** The fully executed Contract, original bonds and insurance certificates and endorsements required under the Contract shall be delivered to the City within ten calendar days of Contractor's receipt of the Notice of Award.

The Engineer will supply Contractor with up to ten sets of the Invitation for Bids and Project Plans. At least one complete set of the Invitation for Bids and Project Plans shall be kept at the construction site in good condition and made available to the Engineer at all times. Additional copies of the Invitation for Bids and Project Plans will be provided by the Engineer at Contractor's cost.

**3-1.20 Failure to Execute Contract:** Contractor's failure to deliver to the City the fully executed Contract within ten calendar days of Contractor's receipt of the Notice of Award shall be cause for the cancellation of the award and the forfeiture of the bid guaranty to the City. If the successful bidder refuses or fails to execute the Contract, the City may award the Contract to the second lowest responsible bidder. If the second lowest responsible bidder refuses or fails to execute the Contract, the City may award the Contract to the third lowest responsible bidder. The refusal or failure by the second or third lowest responsible bidder to deliver to the City the fully executed Contract within ten calendar days of receipt of the Notice of Award to the respective bidder shall likewise be cause for the cancellation of the award and the forfeiture of the bid guaranty of the respective bidder. In its discretion, the City may then re-advertise the project or construct it by day labor.

**3-1.21 Return of Bid Guarantees:** Within ten days after the opening of bids, the City will return the bid guarantees to all bidders except the three lowest responsible bidders. The bid guarantees of the three lowest responsible bidders will be retained until the Contract has been fully executed. In the event all bids are rejected, all bid guarantees will be returned to the respective bidders.

**3-1.22 Subcontractors:** The successful bidder shall furnish a list of all subcontractors as required under Sections 2-1.33C. The list shall include the name, business address, DIR registration number and the state contractor's license number of each subcontractor on the list and the names of the responsible managing employees whose names appear on the subcontractors' licenses.

## 4 SCOPE OF WORK

**4-1.05 Changes and Extra Work:** All changes to the Contract shall be made by written change order only.

All extra work shall be recorded by Contractor on a daily report signed by both the City and Contractor. The “daily reports” shall thereafter be considered the true record of extra work performed. A copy of the daily reports will be furnished to Contractor. Contractor is directed to Section 9-1.04 of this Invitation for Bids.

**4-1.05C Compensation for Altered Quantities:** Payment and compensation for altered quantities shall conform to the provisions of Section 9-1.06 of the Standard Specifications, except as modified herein.

## 5 CONTROL OF WORK

**5-1.02 Contractor's Copies of Contract Documents:** In the event of a conflict in any of the Contract Documents, the order of precedence from highest to lowest shall be as follows:

1. Special Provisions
2. City Standards
3. City Specifications
4. Standard Specifications
5. Standard Plans

**5-1.05 Order of Work:** The work as shown on the Project Plans and as specified in the Invitation for Bids shall be constructed in a sequence that is satisfactory to and approved by the Engineer.

Contractor shall prepare a work schedule per Section 8-1.02 of the Standard Specifications.

With the exception of trenching, all existing street, street light base, curb and gutter, storm drain, water line, and sewer line work shall be completed before any existing street paving is removed.

**You shall furnish the Arborist Report prior to the paving operation as per Section 111 Tree Surgery (Sidewalk Maintenance).**

Full compensation for the conformance to the requirements of this section is included in the Contract price and no additional allowance will be made to Contractor for this work.

**5-1.17 Character of Workers:** Contractor is directed to Section 5-1.17 of the Standard Specifications which states:

"If any subcontractor or person employed by the Contractor shall appear to the Engineer to be incompetent or to act in a disorderly or improper manner, he shall be discharged immediately on the request of the Engineer, and such person shall not again be employed on the work."

No additional compensation shall be granted to Contractor in the event City exercises any part of its rights under this section and any and all costs related to such exercise shall be borne by Contractor.

**5-1.20 Cooperation with Other Entities:** Attention is directed to Section 5-1.20 of the Standard Specifications.

Other construction including but not limited to utility, power, and pipe line relocation, may be in progress by other forces within and adjacent to the project area at the same time work is being performed under this Contract by Contractor.

Contractor shall cooperate with the forces performing other work, to the end that such forces may conduct their operations with as little inconvenience and delay as possible. Contractor shall grant such forces access to the project area as is reasonable and necessary to transport materials and equipment to the site of operations by the other forces.

**5-1.20B(4)(a) Offsite Staging Areas and Construction Yards:** Attention is directed to Santa Rosa City Code section 20-52.040, Temporary Use Permit.

A Temporary Use Permit shall be obtained for any offsite construction yard on private property to be used for any of the following:

- a. Stockpiling of equipment and/or materials;
- b. Staging of construction;
- c. Placement of work trailers or mobile offices;
- d. Storage of trench spoils; or
- e. Other construction related activities not specifically enumerated above.

**5-1.26 Lines and Grades:** Contractor shall carefully preserve all bench marks, grade stakes, and all other survey markers. In the case of willful or careless destruction, Contractor shall bear the cost of replacing the markers.

Contractor shall contact the Engineer directly for coordination of survey staking. Written staking requests must be submitted at least two working days in advance of the date and time stakes are needed.

**5-1.27B Examination and Audit:** Pursuant to California Government Code section 8546.7, any contract with the City involving expenditures in excess of \$10,000 shall be subject to the examination and audit of the California State Auditor for a period of three years after final payment is made to Contractor by City under this Contract. Any such examination and audit will be confined to those matters connected with the performance of this Contract.

**5-1.30A Inspection:** Contractor shall bear all costs associated with the re-inspection of any defective, rejected or unauthorized work as determined by the Engineer in Engineer's sole discretion. Such costs of re-inspection, including any costs incurred by the City for additional staff time or fees for third-party consultant inspectors, will be deducted from one or more progress payments hereunder.

**5-1.36A Property and Facility Preservation:** Attention is directed to Section 5-1.36 of the Standard Specifications.

At Contractor's sole expense, all fences, gates, landscaping, drainage ditches, sidewalks, irrigation systems, and any other improvements that are damaged, removed or destroyed because of Contractor's operations, shall be replaced in accordance with City Standards at a minimum and restored to the same or better condition. Concrete surface treatment and score marks shall match adjacent existing concrete improvements.

**5-1.36E Obstructions:** Attention is directed to Section 5-1.36 of the Standard Specifications and to the possible existence of underground gas mains, high voltage lines, telephone ducts, storm drains and water and sewers systems, the locations of which are not shown on the Project Plans. The determination of the location of these facilities and the cost of repair or replacement in the event of damage to such facilities are the sole responsibility of Contractor.

Should Contractor alter any public utility or private improvements to facilitate its operations or for its sole benefit, which alteration would not be otherwise required, Contractor shall make whatever arrangements are necessary with the owner or controlling authorities, and shall bear all expenses in connection therewith. Any damages to any public utility or private improvement caused by Contractor shall be repaired by Contractor at its sole expense and to the full satisfaction of the Engineer or the controlling authority.

Any subsurface information and data furnished under any part of this Contract are not intended as a representation or warranty but are furnished for information only. It is expressly understood that the City will not be responsible for the accuracy thereof or for any deduction, interpretation or conclusion drawn therefrom by Contractor. The information is made available so that Contractor may have ready access to the same information available to the City and is not part of this Contract.



PRIOR TO STARTING ANY EXCAVATION, CONTRACTOR SHALL (AT LEAST TWO WORKING DAYS IN ADVANCE) CALL UNDERGROUND SERVICE ALERT (USA) toll free at (800) 227-2600 and provide USA with all necessary data relative to the proposed excavation. USA will accept calls and process information to participating agencies who have underground facilities in the area between the hours of 7:30 a.m. and 5:00 p.m. daily, except Saturdays, Sundays, and holidays. Between the hours of 5:00 p.m. and 7:30 a.m., calls will be recorded and then processed after 7:30 a.m. For emergency situations, after hours, and on Saturdays, Sundays and holidays, Contractor shall contact the owner of the affected facility.

Contractor shall coordinate all work with the appropriate City field personnel. When City work forces are required at the job site to perform Contract items of work, Contractor shall give a minimum of two working days advanced notification to the appropriate field office:

Water Division:	(707) 543-4200
Sewer Division:	(707) 543-4200
Street Division:	(707) 543-3880
Survey Division:	(707) 543-3834

**5-1.43 Potential Claims and Dispute Resolution:** "Claim" means a separate demand by Contractor sent by registered mail or certified mail with return receipt requested, for one or more of the following: (A) A time extension, including, without limitation, for relief from damages or penalties for delay assessed by the City under the Contract; (B) Payment by the City of money or damages arising from work done by, or on behalf of, Contractor pursuant to the Contract and payment for which is not otherwise expressly provided or to which the claimant is not otherwise entitled; or (C) Payment of an amount that is disputed by the City.

Upon receipt of a Claim, the City shall conduct a reasonable review of the Claim and, within a period not to exceed 45 days, shall provide Contractor a written statement identifying what portion of the Claim is disputed and what portion is undisputed, provided, the parties may extend the 45 day time period by mutual agreement.

If the City needs approval from the City Council to provide the claimant a written statement identifying the disputed portion and the undisputed portion of the Claim, and the Council does not meet within the 45 days or within the mutually agreed to extension of time following receipt of a Claim, the City shall have up to three days following the next duly publicly noticed meeting of the City Council after the 45-day period, or extension expires to provide Contractor a written statement identifying the disputed portion and the undisputed portion.

Any payment due on an undisputed portion of the Claim shall be processed and made within 60 days after the City issues its written statement. If the City fails to issue a written statement, the Claim shall be deemed rejected in its entirety.

If a Contractor disputes the City's written response, or if the City fails to respond to a Claim within the time prescribed, the Contractor may demand in writing an informal conference to meet and confer for settlement of the issues in dispute. Upon receipt of a demand in writing sent by registered mail or certified mail, return receipt requested, the City shall conduct a meet and confer conference within 30 days for settlement of the dispute. Within 10 business days following the conclusion of the meet and confer conference, if the Claim or any portion of the Claim remains in dispute, the City shall provide the Contractor a written statement identifying the portion of the Claim that remains in dispute and the portion that is undisputed. Any payment due on an undisputed portion of the Claim shall be processed and made within 60 days after the City issues its written statement. Any disputed portion of the Claim, as identified by Contractor in writing, shall be submitted to nonbinding mediation, with the City and the Contractor sharing the associated costs equally. The City and Contractor shall mutually agree to a mediator within 10 business days after the disputed portion of the Claim has been identified in writing. If the parties cannot agree upon a mediator, each party shall select a

mediator and those mediators shall select a qualified neutral third party to mediate with regard to the disputed portion of the Claim. Each party shall bear the fees and costs charged by its respective mediator in connection with the selection of the neutral mediator.

## 6 CONTROL OF MATERIALS

**6-2.01 Source of Supply and Quality of Materials:** All materials required to complete the work under the Contract shall be furnished by Contractor and shall be free of hazardous substances.

**6-3.01 General:** Statistical means will not be used by the City for determination of Standard Specification compliance. Whenever both operating range test results and Contract compliance requirements are specified in these special provisions, the operating range requirements shall apply to the individual test results.

**6-3.01A Material Submittals:** Upon award of the Contract by City, Contractor shall submit to the Engineer a list of all materials proposed to be used on this project and any supporting documentation and/or samples required and source of supply.

For material listed on the “Engineer’s List of Approved Items” which is located in the Sewer and Water sections only of the City Standards, the Engineer shall be provided with the name of the manufacturer and model/part number for all material proposed for this project, unless that item has been replaced as shown on the Project Plans or in the Invitation for Bids.

For all other materials used on this project, regardless of the type of work, Contractor shall provide to the Engineer the name of the manufacturer and model/part number along with supporting documentation and/or samples that will allow the Engineer to determine the material’s acceptability.

The Engineer reserves the right to reject any proposed material, whether on the City’s “Engineer’s List of Approved Items” or not. If the City obtains information indicating that a listed item is not performing satisfactorily or is found to be defective, that item will be rejected and Contractor shall submit a replacement for review at no additional cost to the City.

**6-3.01B Material Guarantee:** Before any contract is awarded, the bidder may be required to furnish samples of materials and detailed descriptions of equipment to be used in the construction of the project. The materials samples may be subjected to the tests provided for in the Standard Specifications or in this Invitation for Bids to determine their quality and fitness for the project. The successful bidder shall unconditionally guarantee project materials and workmanship for a period of one year from the date of recording of the Notice of Completion. The guarantee shall cover 100% of all costs of repairs within the one year period, including all costs of labor, materials, equipment, and incidentals. Except as may be otherwise provided in Section 3-1.05, the successful bidder shall provide a surety bond executed by a corporate surety authorized and admitted to transact a surety business in the state of California in the minimum amount of one-half of the Contract price to cover this guarantee.

**6-3.05 Quality Assurance:** California Test 216 (Relative Compaction) testing will be modified as follows: A mechanical compactor (Ploog Engineering Co. Model M 100 or equivalent) with 10-pound hammer and split compaction molds shall be used in lieu of the specified manual compaction equipment.

California Test 231 (Nuclear Gage Determination of In-Place Density) will be modified as follows: In-place density and relative compaction may be determined on the basis of individual test sites in lieu of the area concept, at the discretion of the Engineer.

### **6-4 Water Utility**

**6-4.01A Construction Water:** All water required for the performance of the work shall be provided by Contractor. Prior to obtaining water from the City's water system, Contractor shall obtain a Water Use Permit from the City of Santa Rosa Water Department and rent a hydrant or bridge meter. Contractor is responsible for the cost of all water and the cost of all deposits, permits and fees.

Contractor is prohibited from operating gate valves or fire hydrants on the City system.

The acquisition of water from the City's water system through un-metered hydrants or other facilities is a violation of City ordinance and State law. The use of water from sources other than the City's water system must be approved by the Engineer in advance of the use.

Citations and fines will be levied for violation of these and other utility regulations and deductions will be made from payments consistent with Section 7-1.02A(1) of the Standard Specifications.

**6-4.01B Water Utility Notification:** Contractors or parties requiring work of any kind by the City of Santa Rosa Water Department forces shall request such services a minimum of 48 hours in advance of the time such services are desired. Work requests which will involve the City of Santa Rosa Water Department forces for more than eight hours or an extensive number of City parts shall be requested a minimum of seven calendar days in advance.

If it is necessary to terminate or disrupt utility service to any customer, Contractor shall make the request for such work by City forces an additional 72 hours (three additional working days for a total of five working days advance notice) in advance of the time such services are desired to allow affected customers a minimum of 72 hours' notice. Contractors who fail to keep field appointments will be billed for scheduled City of Santa Rosa Water Department crew standby time which was used and the Contractor shall bear the costs incurred by the City of Santa Rosa's Water Department for re-notification of customers.

City of Santa Rosa Water Department crews work a 9/80 schedule. This schedule may prohibit shutdowns for tie-ins on alternating Fridays. After hours work or weekend work may be performed if prior authorization from the Engineer is obtained.

Other than the hours specified in this Invitation for Bids, requests by Contractor for after hours or weekend work is to be avoided whenever possible. Any overtime costs incurred by City for such work shall be borne by Contractor.

Interruption of utilities service to commercial customers shall be coordinated with the customer to minimize disruption to the enterprise to the greatest extent practicable. After notification by the Contractor of the need, the City of Santa Rosa Water Department will contact all commercial customers and inform Contractor accordingly.

**6-4.01C Water Facility Damage:** All damage caused to the City's water system shall be immediately reported to the Engineer.

Damage caused to the City's water system by Contractor's operations shall be repaired by the Contractor at Contractor's sole expense in a manner satisfactory to the City of Santa Rosa Water Department. Such repairs shall not be charged to the City or any City project. All repair work shall be witnessed and approved by the City of Santa Rosa Water Department prior to backfilling the excavation. The City will require re-excavation if backfilling occurs prior to inspection, which costs shall be borne by Contractor.

Contractor is responsible for, at its sole cost and expense, the repair and remediation of damage to property and facilities caused by any of the following circumstances:

- a. Contractor fails to make a written request for a markout or begins excavation without providing the City of Santa Rosa Water Department a reasonable opportunity to mark facilities;
- b. Contractor destroys markouts;
- c. Contractor fails to perform hand digging or probing for utilities near markouts; or
- d. Contractor fails to use reasonable caution, regardless of whether markouts are present or clear. Reasonable caution includes any efforts to avoid damaging existing facilities, such as when excavating in the vicinity of water mains.

City may, in its discretion, opt to make the repairs for which Contractor is responsible with its own forces. In such cases, the repairs will be made at Contractor's expense in accordance with the emergency repair rate schedule of the City of Santa Rosa Water Department. The City may make repairs whenever restoration of service requires extraordinary speed or special equipment. Contractor will be billed accordingly and City shall have the right and option to withhold payment hereunder, or a portion thereof, for any such costs billed but not promptly paid by Contractor.

**6-4.02 Salvage:** All valves, hydrants, and other appurtenances of the water system that are the property of City and removed by Contractor shall be delivered to the City's Municipal Services Center (55 Stony Point Road) unless Contractor has obtained specific written approval from the City of Santa Rosa Water Department to otherwise dispose of the materials.

**6-4.03 Trade Names and Alternatives:** Unless otherwise specified, material and equipment specifications that identify a particular patent, trade name or manufacturer, may be satisfied through substitute materials and equipment accepted by the City. Contractor may offer substitute materials and equipment of equal or better quality to the City. Any such offer shall be made in writing to the Engineer at least four weeks in advance of the time Contractor wishes to order the materials or equipment. Contractor shall include sufficient data which, together with any other information the Engineer may require, will enable the Engineer to determine the acceptability of the materials and equipment. When the substitute materials or equipment necessitate changes to any part of the work, the information shall include drawings and details showing all such changes and Contractor shall perform these changes as a part of any acceptance of substitute materials or equipment. The use of substituted materials and equipment will be permitted only after written acceptance of the materials and equipment by the Engineer. Such acceptance shall not relieve the Contractor from full responsibility for the sufficiency, quality and performance of the substitute materials and equipment.

The City will not, under any circumstances, acknowledge or consider any offers to accept substitute materials or equipment between the dates of public notice of advertisement and the bid opening.

## 7 LEGAL RELATIONS AND RESPONSIBILITY TO THE PUBLIC

**7-1.02A(1) Forfeitures for Health and Safety Violations:** Contractor shall comply with all applicable provisions of the Santa Rosa City Code and any failure to do so shall constitute a breach of the Contract. In the event of any violation of the Santa Rosa City Code that may impact public health and safety, including, but not limited to Chapter 17-12, "Storm Water" and Chapter 13-04, "Street Encroachments," City shall have the right to impose a charge against Contractor in an amount equal to \$500.00 per violation per day. Prior to the imposition of any charge hereunder, City shall first provide a written notice to Contractor of the violation and setting forth a reasonable period of time for Contractor to cure the violation(s). In the event Contractor fails to cure any such violation within the time provided, City shall have the right, in addition to all other rights and remedies available to City, to deduct and withhold as a permanent forfeiture by Contractor the appropriate amounts from any payment otherwise due Contractor under this Contract.

**7-1.02K(2) Wages:** Pursuant to Labor Code sections 1770 *et seq.*, each laborer or mechanic of Contractor or any subcontractor engaged in work on the project under this contract shall be paid not less than the hourly wage rate of per diem wages set forth in the prevailing wage rate schedule published by the Director of Industrial Relations, regardless of any contractual relationship which may be alleged to exist between Contractor or any subcontractor and such laborers and mechanics. A copy of the schedule of prevailing wage rates can be obtained online at [www.dir.ca.gov](http://www.dir.ca.gov) or from the Department of Transportation and Public Works at 69 Stony Circle, Santa Rosa.

Any laborer or mechanic employed to perform work on the public works project under this Contract, which work is not covered by any of the foregoing classifications, shall be paid not less than the prevailing wage rate of per diem wages specified herein for the classification which most nearly corresponds to the work to be performed by the worker.

The foregoing specified prevailing wage rates are minimum rates only, and Contractor may pay any wage rate in excess of the applicable rate.

Pursuant to Labor Code Section 1775, Contractor as a penalty to the owner shall forfeit not more than \$200.00 for each calendar day, or a portion thereof, for each worker paid less than the prevailing wage rate established by the Department of Industrial Relations for such work or craft in which such worker is employed. The difference between such prevailing wage rates and the amount paid to each worker for each calendar day or portion thereof for which the worker was paid less than the prevailing wage rate shall be paid to each worker by Contractor.

Contractor shall only provide prevailing wage reports upon written request from City.

**7-1.02K(4) Apprentices:** Contractor agrees to comply with Chapter 1, Part 7, Division 2, sections 1777.5 *et seq.* of the California Labor Code. These sections require contractors and subcontractors to employ apprentices in apprenticeable occupations in a ratio of not less than one hour of apprentice work for each five hours of journeyman work (unless an exception is granted in accordance with Section 1777.5), and the contractors and subcontractors shall not discriminate among otherwise qualified employees as apprentices solely on the ground of sex, race, religion, creed, national origin, ancestry, or color. Only apprentices as defined in Labor Code section 3077, who are in training under apprenticeship standards and who have written apprentice agreements will be employed on public works in apprenticeable occupations. The responsibility for compliance with these provisions is fixed with the prime contractor for all apprenticeable occupations.

**7-1.02K(6)(a)(1) Notice to Vendors:** Attention is directed to the current OSHA Standards. All equipment, tools and materials which are furnished and/or installed as part of this Contract shall meet or exceed the aforementioned standards in order to be considered acceptable.

**7-1.02K(6)(b) Excavation Safety:** When the digging or excavation occurs during project construction, Contractor shall:

- a. Promptly notify City in writing of the following conditions before any such conditions are disturbed:
  1. Material that the Contractor believes may be hazardous waste as defined in Health and Safety Code section 25117 that is required to be removed to a Class I, Class II or Class III disposal site in accordance with provisions of existing law;
  2. Subsurface or latent physical conditions at the site differing from those indicated in the Invitation for Bids; and
  3. Physical conditions at the site of any unusual nature, materially different from those ordinarily encountered and generally recognized as inherent in the type of work under the Contract.
- b. The City will investigate the conditions and will issue a change order under the terms of the Contract if it finds that the conditions warrant it.
- c. If a dispute arises between City and Contractor as to whether a change order is warranted, Contractor shall not be excused from any scheduled completion date provided for in the Contract, but shall proceed with all work to be performed under the Contract.

**7-1.02K(6)(b)(1) Trench Excavation Safety Plans:** When the estimated cost for the excavation of any trench or trenches five feet or more in depth will exceed \$25,000.00, Contractor shall submit to the Engineer in advance of excavation a detailed plan showing the design of shoring, bracing, sloping or other provisions to be made for worker protection from the hazard of caving ground during the excavation of such trench or trenches. If such plan varies from the shoring system standards established by the construction safety orders, or if the trench is anticipated to be greater than 20 feet, the plan shall be prepared by a registered civil or structural engineer.

A permit to do the above described work shall be obtained from the State of California, Division of Industrial Safety. Proof of such permit shall be submitted to the Engineer prior to starting the trench work.

Full compensation for complying with the provisions of this section shall be considered as included in the Contract price and no additional allowance will be made for the work.

**7-1.02K(6)(d) Confined Space Safety:** Any confined space entry for this project, including but not limited to manhole or water storage tank entry, will require a confined space entry permit pursuant to Cal/OSHA regulations as set forth in title 8 California Code of Regulations (CCR) sections 5157 or 5158. Confined space entry shall have the meaning ascribed in title 8 CCR sections 5157 and 5158. For any confined space entry for construction operations regulated by title 8 CCR section 1502, Contractor shall comply with title 8 CCR section 5158, "Other Confined Space Operations." For any other confined space operations, Contractor shall comply with title 8 CCR section 5157, "Permit-Required Confined Spaces."

Attention is directed to the technical specifications in the Special Provisions for information regarding entry to any City maintained confined space. Pursuant to title 8 CCR section 5157, Contractor is required to obtain any available information regarding hazards and operations for any City maintained confined spaces. The City maintained Confined Space Entry Manual is available

for viewing at the City of Santa Rosa Water Department or Transportation and Public Works Department office at 69 Stony Circle, Santa Rosa.

Contractor shall immediately inform the Engineer of any previously unidentified hazards confronted or created during confined space entry.

**7-1.02L(2)(a) Patents and Royalties:** All fees, royalties, or claims for any patented invention, article, process or method that may be used upon or in any manner connected with the work under this Contract shall be paid by Contractor. Contractor and its sureties shall protect and hold harmless City and its officers, agents, and employees from any and all demands made for such fees royalties or claims brought or made by any third party, and before the final payment is made on the account of the Contract, Contractor shall, if requested by City, furnish acceptable proof of a proper release from all such claims and liabilities.

Should Contractor, its officers, agents, or employees, or any one of them be enjoined from furnishing or using any invention, article, material, or plans supplied or required to be supplied or used under the Contract, Contractor shall promptly substitute other articles, materials, or appliances in lieu thereof of equal efficiency, quality, finish, suitability, and market value, and satisfactory in all respects to the Engineer. In the event that the Engineer elects, in lieu of such substitution, to have supplied and to retain and use any such invention, article, materials, or plans as may be required to be supplied by the Contract, Contractor shall pay such royalties and secure such valid licenses as may be requisite and necessary for City, its officers, agents, and employees, or any one of them to use such invention, article, materials, or appliance without being disturbed or in any way interfered with by any proceeding in law of equity on account thereof. Should Contractor neglect or refuse to make the substitution promptly or to pay such royalties and secure such licenses as may be necessary, then in that event the Engineer shall have the right to make such substitutions or City may pay such royalties and secure such licenses and charge Contractor even though final payment under the Contract may have been made.

**7-1.02M(3) Mined Materials:** California Public Contract Code section 20676 prohibits surface mining operators which are subject to the Surface Mining and Reclamation Act of 1975 (SMARA) from selling California mined construction material to the City unless the operator is identified in a list referred as the **3098 List**. The List, which is maintained by the Department of Conservation's Office of Mine Reclamation (OMR), changes throughout the year and can be viewed at the OMR website: [http://www.consrv.ca.gov/OMR/ab\\_3098\\_list/index.htm](http://www.consrv.ca.gov/OMR/ab_3098_list/index.htm). To confirm whether or not a specific operator is on the List at any given time, Contractor shall call the OMR at (916)323-9198.

**7-1.03A Maintaining Traffic:** Attention is directed to Sections 7-1.04 of the Standard Specifications and to the following modifications thereof.

If construction is within City owned right-of-way, provisions shall be made for the safe passage of public traffic through the work site at all times consistent with the requirements of Santa Rosa City Code Chapter 13-04.

Except for projects to be performed under a minor contract, Contractor shall install and maintain project identification signs at each end of the project or as directed by the Engineer two weeks prior to any construction activity. City shall furnish the appropriate sign panels upon request from Contractor. To mount the sign panels, Contractor shall furnish and install 4" X 4" posts or mount by other appropriate methods as approved by the Engineer. These sign panels shall be returned to the City Corporation Yard at 55 Stony Point Road after completion of the project.

Two weeks prior to any construction activity, advance notice signs for road closures shall be furnished and installed by Contractor at each end of the project and shall remain in place throughout the duration of the subject closure. Details of panel construction and lettering shall be approved by the Engineer.



Contractor shall furnish, install, and maintain at its expense all barricades, signs, lights, and other devices necessary to adequately warn of any obstructions to the traveled and pedestrian way and provide flaggers as necessary for the safety of public traffic and pedestrians and to provide access to property adjacent to the work site and Contractor shall comply with the Americans with Disabilities Act of 1990 (42 U.S.C. 12101, *et seq.*) (ADA) and any regulations and guidelines issued pursuant to the ADA.

Contractor shall comply with the current edition of the California Manual of Uniform Traffic Control Devices (CA MUTCD) for all items related to traffic within the work site.

Rain and other occurrences that may cause the suspension or delay of the work shall in no way relieve Contractor of its responsibility to provide traffic control and public access through the work site as specified herein. At all times, Contractor shall keep at the work site such materials, forces and equipment as may be necessary to keep roads, streets, and driveways within the work site open to traffic and in good repair and shall expedite the passage of such traffic, using such forces and equipment as may be necessary.

Should Contractor fail, in the opinion of the Engineer, to provide all the materials, forces and equipment necessary to maintain traffic through the work site as set forth herein, City may take steps necessary to remedy any such failure, including but not limited to causing such work to be performed and/or suspending any further work under the Contract. Any such remedial cost and expense incurred by the City, plus an administrative charge of 15%, shall be immediately due and payable by Contractor and may be deducted from any amounts owed to Contractor hereunder. In the event there are insufficient sums owed to Contractor hereunder to cover the foregoing costs and charges, City shall have the right to pursue any other remedy to recover the same, including but not limited to, proceeding against any surety or bond in favor of City. City's rights under Section 7-1.02 are intended to be in addition to and not in lieu of any charges imposed by City against Contractor under Section 7-1.02A(1) above for violations of the Santa Rosa City Code.

Contractor shall be responsible for informing emergency response agencies operating within the area of the work of obstructions to either public or private roads caused by reason of Contractor's operations hereunder.

Contractor shall make provisions for the safe passage of pedestrians around the project work site at all times.

## 8 PROSECUTION AND PROGRESS

**8-1.01A Assignments:** Once awarded, this Contract shall not be transferred, assigned, or sub-contracted, except as herein expressly provided without the prior written consent of the City in the City's sole and absolute discretion. See Section 5-1.12 of the Standard Specifications.

**8-1.04B Standard Start:** Contractor shall begin work within ten calendar days after the date authorized in the Notice to Proceed and shall diligently prosecute the Contract to completion before the expiration of:

45 WORKING DAYS

**8-1.05 Time:** Working days will be counted beginning with the day the Contractor begins work or with the tenth day after the date authorized in the Notice to Proceed, whichever occurs first.

Unless otherwise directed by Engineer, Contractor shall not conduct any activities that generate noise earlier than 8:30 a.m. or later than 4:00 p.m.

**8-1.10 Liquidated Damages:** Contractor hereby agrees that Contractor shall pay to the City liquidated damages for each and every calendar day delay over and above the number of working days prescribed above for finishing the work in the amount shown in Section 8-1.10 of the Standard Specifications.

## 9 MEASUREMENT AND PAYMENT

**9-1.04 Force Account Work:** All work done on a force account basis shall be recorded daily on report sheets prepared by Contractor and signed by both the Engineer and Contractor. Such reports shall thereafter be considered the true record of force account work performed during the project. Such reports shall be furnished to the Engineer and a copy retained by Contractor.

All extensions of labor, equipment, and material costs shall be completed by Contractor and submitted to the Engineer within 30 days of the completion of the extra work. Completed and extended extra work reports received later than the times herein prescribed may be deemed invalid and rejected without payment at the discretion of the Engineer.

**9-1.07 Payment Adjustments For Price Index Fluctuations:** Any references to Opt Out of Payment Adjustments for Price Index Fluctuations in the Standard Specifications are deleted in their entirety.

**9-1.16 Progress Payments:** Once each month for progress pay purposes, the City will prepare a written estimate of the total amount of completed work and accepted materials purchased by Contractor but not installed. The City shall retain five percent of such estimated value of the completed work and the unused materials and pay Contractor the balance after deducting all previous payments and all sums to be retained under the provisions of the Contract. No such estimate or payment shall be required to be made when, in the judgment of the Engineer, the work is not proceeding in accordance with the provisions of the Contract or when, in the Engineer's judgment, the total value of the completed work since the last estimate is less than \$500.00. No such estimate or payment shall be construed to be an acceptance of any defective work or improper materials.

After Contract acceptance, the Engineer will prepare a written proposed final estimate of the proposed final quantities of work completed under the Contract and the value of such work and will submit such estimate to Contractor. The City shall retain five percent of such estimated value of the work done and shall pay to Contractor the balance after deducting all amounts to be retained under the provisions of the Contract.

The City may, at its option and at any time, retain out of any amounts due Contractor sums sufficient to cover any unpaid claims of City or others, provided that sworn statements of all non-City claims shall have been filed with the Director of Finance.

**9-1.16E(6) Substitution of Securities for Withheld Amounts:** Pursuant to Public Contract Code section 22300, securities may be substituted for any moneys withheld by City to ensure performance under this Contract, provided that substitution of securities provisions shall not be required in contracts in which there will be financing provided by the Farmer's Home Administration of the United States Department of Agriculture pursuant to the Consolidated Farm and Rural Development Act (7 USC sections 1921 *et seq.*), and where federal regulations or policies or both do not allow the substitution of securities. At the request and expense of Contractor, securities equivalent to the amount withheld shall be deposited with the City, or with a state or federally chartered bank as the escrow agent, which shall then pay such moneys to Contractor. The Director of Finance is authorized to execute substitution of securities agreements on behalf of the City. The City will return the securities to Contractor upon satisfactory completion of the Contract as determined by City in its sole discretion and the resolution of all outstanding claims against the securities. Contractor shall be the beneficial owner of any securities substituted for moneys withheld and shall receive any interest thereon.

Securities eligible for investment under this section shall include those listed in Government Code section 16430, bank or savings and loan certificates of deposit, interest bearing demand deposit accounts, standby letters of credit or any other security mutually agreed to by Contractor and the City, provided that the substituted security is equal to or not less than five percent of the Contract amount.

Security substitutions must be submitted by Contractor and approved by City prior to the time of the first progress payment to be made under the Contract. No other method of substituting securities for retention will be accepted. The security substitution shall be done only upon execution of an agreement satisfactory to City which includes the following provisions:

- a. The amount of securities to be deposited;
- b. The terms and conditions of conversion to cash in case of the default of Contractor;  
and
- c. The procedure for return of securities upon completion of the Contract.

**9-1.17D Final Payment and Claims:** The processing of payment of the final estimate shall not be commenced less than 35 days after the date of recording of the Notice of Completion with the County Recorder's Office. Contractor is advised that it takes approximately ten days for a check to be issued following a request for payment.

Contractor shall submit its written statement of all claims for additional compensation under the Contract to the Engineer within 15 days after submission to Contractor of the proposed final estimate.

If Contractor does not file a claim within the 15 day period, or upon Contractor's approval, the Engineer will issue a final written estimate and the City shall pay to Contractor the entire sum due after deducting all previous payments, if any, and all amounts to be retained under the provisions of the Contract.

If Contractor files a claim within the 15 day period, the Engineer will furnish a semi-final estimate and pay the amount due under the semi-final estimate within 30 days. The semi-final estimate is conclusive as to the amount payable except as may be affected by claims and any amount retained. The Engineer shall then consider and investigate such claim, and shall make such revision in the final quantities as the Engineer may find to be due, and shall then make and issue a final written estimate. The City will pay the amount due, after deducting all previous payments, if any, and amounts to be retained under the provisions of the Contract.

Any and all prior partial estimates and payments shall be subject to correction in the final estimate and payment.

The final estimate shall be conclusive and binding against both parties to the Contract on all questions relating to the performance of the Contract and the amount of work done thereunder and compensation therefor, except in the case of gross error.

**9-1.17D(3) Final Determination of Claims:** Claims filed by Contractor shall be in sufficient detail to enable the Engineer to determine the basis and amount of the Claims. Contractor shall also furnish reasonable documentation to the City to support Claims. If additional information is required by the Engineer, Contractor shall provide such information to the Engineer no later than the 15<sup>th</sup> day after receipt of the written request from the Engineer. If the 15<sup>th</sup> day falls on a weekend, holiday, or day City offices are closed, then the information shall be provided to the Engineer no later than close of the next business day. Failure to submit the requested information to the Engineer within the time specified will be sufficient cause for denying the Claim.

Contractor shall keep full and complete records of the costs and additional time incurred for any work for which a claim for additional compensation is made. The Engineer or any designated Claim

investigator or auditor shall have access to those records and any other records as may be reasonably required by the Engineer to determine the facts or contentions in each Claim. Failure to grant access to such records shall be sufficient cause for denying the Claims.

**9-1.22 Arbitration:** Any references to Arbitration in the Standard Specifications are deleted in their entirety.

Claims submitted by Contractor shall be accompanied by a notarized certificate containing the following language:

Under the penalty of law for perjury or falsification and with specific reference to the California False Claims Act, Government Code sections 12650 *et seq.*, the undersigned,

\_\_\_\_\_  
(Name)

\_\_\_\_\_ of  
(Title)

\_\_\_\_\_  
(Contractor)

hereby certifies that the claim for additional compensation made herein is supported by a true statement of the actual costs incurred and time expended on this project, and is fully documented by records maintained by Contractor.

Dated \_\_\_\_\_

/s/ \_\_\_\_\_

Subscribed and sworn before me this \_\_\_\_\_ day of

\_\_\_\_\_

\_\_\_\_\_  
Notary Public

My Commission Expires \_\_\_\_\_

Failure to submit the notarized certificate will be sufficient cause for denying the claim.

Any claim for overhead expenses, in addition to being certified as stated above, shall be supported by an audit report of an independent Certified Public Accountant. Any such overhead claim shall also be subject to audit by the City at its discretion.

Any costs or expenses incurred by the City in reviewing or auditing any claims that are not supported by Contractor's cost accounting or other records shall be deemed to be damages incurred by the City within the meaning of the California False Claims Act.

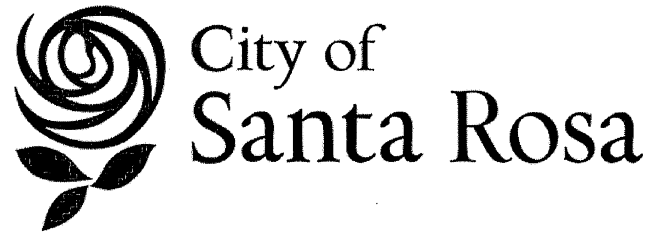

**TECHNICAL SPECIFICATIONS**

**FOR**

**ROSELAND PAVEMENT MAINTENANCE**

**CONTRACT NO. C02113**

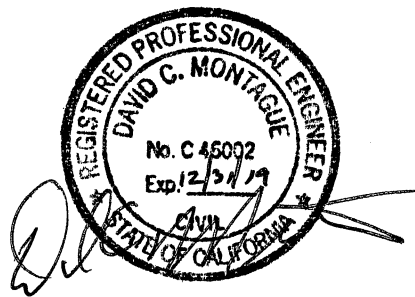

**2019**

# 12 TEMPORARY TRAFFIC CONTROL

## **12-1 General**

**12-1.01 General:** Construction area traffic control devices shall be installed and maintained in accordance with the applicable sections of these Special Provisions, the Standard Specifications, the current Edition of the California Manual on Uniform Traffic Control Devices (CA MUTCD), the Americans with Disabilities Act (ADA) and as directed by the Engineer.

**12-1.03 Flagging Costs:** The first paragraph of Section 12-1.03, "Flagging Costs" is amended to read:

"The cost of furnishing all flaggers, including transporting flaggers, to provide for passage of public traffic through the work under the provisions in Section 7-1.08, "Public Convenience", and Section 7-1.09, "Public Safety", shall be considered as included in the contract lump sum price paid for traffic control and no additional allowance will be made therefor."

## **12-3 Traffic-Handling Equipment and Devices**

**12-3.01 General:** Prior to commencing construction which will affect existing vehicular and pedestrian traffic, you shall submit for review by the Engineer, Traffic Control Plans on 11" x 17" sheets of paper which contains only information specifically related to work zone vehicular and pedestrian traffic control. If you propose to use the current edition of the CA MUTCD published by Caltrans in lieu of a traffic control plan, in specific work operations, you shall submit in writing for consideration which Typical Application Diagram will be used and how it will be applied for each work operation. Traffic Control Plans or proposals shall be submitted for review at least two weeks prior to implementation.

Traffic Control Plans shall contain a title block which contains your name, address, phone number, project superintendent's name, contract name, dates and hours traffic control will be in effect, and a space for review acknowledgment.

The content of the Traffic Control Plan shall include, but is not limited to, the following:

1. Show location and limits of the work zone.
2. Give dimensions of lanes affected by traffic control that will be open to traffic.
3. Indicate signing, cone placement, and other methods of delineation and reference to appropriate City or Caltrans Standards.
4. Dimension location of signs and cone tapers.
5. Identify side streets and driveways affected by construction and show how they will be handled.



6. Show how pedestrian traffic will be handled through the construction site. Pedestrian pathways through the work zone shall be in compliance with the requirements of ADA during and after work hours.
7. Demonstrate how two-way traffic will be maintained.

No work except for installation of project identification signs will be allowed to commence prior to approval of the Work Zone Traffic Control Plans.

**12-3.02 Payment:** Full compensation for providing traffic control plans is considered as included in the prices paid for various contract items of work and no additional allowance will be made therefor

## **12-4 Maintaining Traffic**

### **12-4.01 Maintaining Traffic:**

1. The full width of the traveled way shall be open for use by public traffic on Saturday, Sundays and designated legal holiday(s), after 4:00 p.m. on Fridays and the day preceding designated legal holidays, and when construction operations are not actively in progress; unless work has specifically been authorized by the Engineer.
2. The location of traffic control signing, barricades, and other facilities shall be monitored frequently (four to five times per day) by you to verify their proper location. All traffic signal and other traffic control devices shall be maintained at all times.
3. You shall conduct your operations so as to cause the minimum obstruction and inconvenience to traffic and to places of business, multiple dwelling units and residences adjacent to the work. You shall notify the Engineer of your planned work and utility service interruption at least five working days in advance to allow time to notify residents and businesses.
4. When construction activities will prevent vehicle access to individual driveways you shall notify the affected businesses and residents per Section 12-1.03, "Traffic Control", of these Special Provisions. **Full access shall be provided to all driveways during non-working hours.**
5. At locations where traffic is routed perpendicular to trench excavation, the excavation shall be conducted in a manner to provide a surface reasonably satisfactory for traffic at all times. Substructure installation or construction shall be conducted on only one-half the width of the roadway at a time, and that portion of the roadway being used by traffic shall be kept open and unobstructed until the opposite side of the roadway is ready for use. Upon completion of the rough grading, the surface of the roadbed shall be brought to a smooth, even condition free from humps and depressions and made satisfactory for traffic.

**12-4.01A Construction Traffic:** You shall submit a trucking route along with the traffic controls plans for approval by the Engineer. The route must minimize traffic on residential streets that are not part of the project.

Existing pavement damaged by your operations and not shown to be replaced shall be replaced at your expense, per City Standards and to the satisfaction of the Engineer.

**12-4.02 Closure Requirements:** Attention is directed to Section 7-1.03, "Maintaining Traffic", to Section 5-1.05, "Order of Work," of these Special Provisions.

Exact locations of Project Identification signs and Advance Notice signs (Section 7-1.03 "Maintaining Traffic") shall be determined in the field by the Engineer.

Lane closures will be permitted between the hours of 8:30 a.m. and 4:00 p.m. only. Only one lane at a time may be closed and no lanes shall be closed at any other hours unless specifically approved by the Engineer. You shall maintain vehicle access to homes and other properties at all times while work is in progress.

You shall not park construction vehicles, contractor employee vehicles, stage materials or stockpiles in front of any business or residential driveway access and you shall maintain access to private parking lots within the block where work is in progress. Construction vehicles shall not be left running for any length of time if parked in front of a business or residential unit.

On identified local/residential streets you will normally be allowed use of each block (between nearest intersections) for your sole use, without the need to provide 2-way traffic through that block. You will be required to maintain vehicle access to homes and other properties within the block where work is in progress.

You shall keep the City of Santa Rosa Fire Department informed regarding the closure of any traveled way. At a minimum, you shall call the Fire Department at 543-3535 or 543-3500 **and** the Communications Center at 543-3666 **daily** to report any traveled way closure. This means immediately upon closure for that day and again immediately after removal of the closure. For closures over multiple days, the daily notification still applies. This requirement does not apply for single lane closures on multiple lane streets.

You shall notify the local Postal Service at (707) 526-0113 and Santa Rosa Recycling and Collection at (707) 586-8234 5 calendar days prior to any lane closures or restrictions in turning movements.

If you have been given an approved Traffic Control Plan that includes road closures, you shall maintain vehicular access to homes and other properties where work is in progress within the closure area.

Where necessary, and only after receiving written approval from the Engineer, you may temporarily suspend curb side parking in the immediate work zone. Notification to businesses and residents shall be hand delivered at least 72 hours prior to construction in the affected areas.

Notification shall be as follows:

1. A notice placed on the front door of each home or business where curb side parking will be suspended and attempt made to notify each business or resident verbally that work will be underway within the block and that curb side parking will be suspended during stated working hours and request that vehicles be parked out of the roadway by 8:00 a.m. Service of notice shall not bar use of cars within the block, as individual plans change and emergencies arise.

2. Type 1 barricades every 50 (100 feet depending on street) feet adjacent to the curb where parking will be suspended with a notice posted on the barricade stating specific dates and times that curb side parking will be temporarily suspended. If work will not take place in the posted area, then you shall remove "No Parking" notices.

You shall maintain vehicle access to all homes and other properties along the work zone. During paving operations, you will be allowed to temporarily suspend vehicle access to a limited number of driveways when approved by the Engineer. When approved by the Engineer and at least 72 hours prior to suspending access to any driveway, you shall give both written and verbal notice to the affected businesses and residents and place barricades adjacent to the driveways with posted notices stating the specific dates and times of the suspension for that area. The notice shall also indicate an alternate parking location. Suspension of access to driveway will be permitted only as approved by the Engineer and only between the hours of 8:00 am and 4:30 pm.

Cross streets will require maintenance of at least one-half (1/2) width of each street for traffic purposes, unless a parallel route is approved by the Engineer. Flagging will only be allowed between the hours of 8:30 am and 4:00 pm.

Barricades and flaggers shall be positioned to allow safe turns at intersections and curves.

You shall maintain traffic control as necessary and as directed by the Engineer for "cat-tracking" operations by City Forces. Flaggers, barricades, signing, etc., shall remain in place for protection of City personnel until such time as all temporary lane delineation is complete.

## **12-7 Temporary Pedestrian Walkways**

**12-7.01 Pedestrian Traffic Control:** You are directed to Chapter 6D, Pedestrian and Worker Safety, in the CA MUTCD, the improvement plans and these Special Provisions.

Pedestrians shall be provided with a safe convenient and accessible path that, at a minimum, replicates the most desirable characteristics of the existing sidewalk, path or footpath. At no point along the road shall the sidewalks on both sides of the road be closed at the same time.

You shall construct and maintain temporary pedestrian pathways through the work zone, where required, that shall be in compliance with the requirements of the Americans with Disabilities Act (ADA), and the CA MUTCD.

Pedestrian routes shall not be impacted for the purposes of any non-construction activities such as parking of vehicles or equipment, or stock piling of materials. Pedestrians shall not be led into conflicts with work site vehicles, equipment or operations.

Pedestrian routes shall be open and accessible at the end of the work day unless an alternate ADA compliant route has been approved by the Engineer. The construction of curb ramps and/or long sections of sidewalk do not alleviate you from this requirement.

## **12-9 Measurement and Payment**

**12-9.01 Payment:** **Traffic Control** shall be paid for at the contract **lump sum** price, which price shall include full compensation for furnishing all labor, materials, tools and equipment, and doing all work involved in **vehicular and pedestrian traffic control**, including but not limited to, providing, placing, maintaining, and removal of temporary paths and/or ramps, temporary relocation of regulatory signs, project and public notification signs, flagging, excavation, compaction, furnishing, and placement of asphalt concrete and/or PCC, barricades, toe-rails, hand rails, complying with CA MUTCD Standards for Pedestrian Safety, coordination efforts and any other items necessary for vehicle and pedestrian traffic control not specifically enumerated in the plans or these specifications, and no additional allowance will be made therefor.

# 13 WATER POLLUTION CONTROL

## **13-1 General**

**13-1.01A:** Water Pollution Control shall be performed in accordance with Section 13, Water Pollution Control of the Standard Specifications and these technical specifications. In addition, construction activities shall comply with:

1. The current California Water Quality Control Board, North Coast Region Order No. R1-2015-0030 National Pollutant Discharge Elimination System Municipal Storm Water Permit, commonly referred to as the "Storm Water Permit". A copy of the Storm Water Permit is available for review at the City of Santa Rosa Transportation and Public Works Department, 69 Stony Circle, Santa Rosa, CA, and at [www.srcity.org/stormwaterpermit](http://www.srcity.org/stormwaterpermit).
2. The California Stormwater Quality Association Storm Water BMP Handbook for Construction (CASQA Handbook). BMPs shall be selected, installed and maintained in accordance with the latest edition. A copy of the handbook can be viewed at the City of Santa Rosa Department of Transportation and Public Works office at 69 Stony Circle or downloaded from CASQA, <http://www.casqa.org/>.

In this technical specification the CASQA Handbook BMP numbers are appended to the associated Standard Specification sections. If a conflict occurs the CASQA Handbook BMP's shall govern.

## **13-2 Water Pollution Control Program**

**13-2.01B Submittals:** The program to control water pollution required to be submitted under this section of the Standard Specifications shall include a spill contingency plan that establishes clean-up procedures that will be followed in the event of a spill of potentially hazardous, toxic, or polluting materials.

**13-2.04 Payment:** The City pays you to prepare a **Water Pollution Control Program** at the **lump sum** price for Water Pollution Control Program .

## **13-3 Storm Water Pollution Prevention Plan**

**13-3.01A Summary:** This project is exempt from the State Water Resources Control Board General NPDES Permit for the Discharge of Storm Water related to Construction Activities (Construction General Permit), and not required to have a Storm Water Pollution Prevention Plan (SWPPP), therefore Section 13-3, Storm Water Pollution Prevention Plan, of the Standard Specifications does not apply to this project.

## **13-4 Job Site Management**

**13-4.03B: Spill Prevention and Control/CASQA Spill Prevention and Control (BMP WM-4):** If a spill occurs at the construction site and you do not take immediate and adequate steps to contain and clean up the spill, especially if rain is threatening or if a discharge to a storm drain or creek could occur, the City shall have the right, in its sole

and absolute discretion, to clean up the spill using City forces or an independent contractor. The cost of any such cleanup, in addition to recovery of any penalty or fine imposed upon the City, plus an administrative charge of fifteen percent (15%) of the costs incurred by the City, shall be deducted from any amounts owed to you hereunder.

In the event there are insufficient amounts owed to you hereunder to cover the foregoing costs and charges, the City shall have the right to pursue any other remedy to recover same, including, but not limited to, proceeding against any surety or bond in favor of the City. The City's rights under this section are intended to be in addition to and not in lieu of any imposed by the City against you for violations of City Code Chapter 17-12, "Storm Water".

**13-4.03C(2): Material Storage/CASQA Material Delivery and Storage (BMP WM-1)**

**13-4.03C(3): Stockpile Management/CASQA Stockpile Management (BMP WM-3):**

Do not block storm water flows.

**13-4.03D(1): Waste Management/CASQA Solid Waste Management (BMP WM-5):** You shall dispose of all trash, rubbish, and waste materials of any kind generated by the contractor, subcontractor, or any company hired by you on a daily basis.

**13-4.03D(3): Concrete Waste/CASQA Concrete Waste Management (BMP WM-8):**

Ensure the containment of concrete washout areas and other washout areas that may contain pollutants so there is no discharge into the underlying soil and onto the surrounding areas.

**13-4.03D(4): Sanitary and Septic Waste/CASQA Sanitary and Septic Waste Management (BMP WM-9):**

Sanitation facilities must be maintained periodically by a licensed service to keep them in good working order and prevent overflows. Portable toilets are required to have secondary containment.

**13-4.03D(5): Liquid Waste:**

Liquid waste includes water generated from excavation dewatering. Minimize transfer piping by locating containers near the excavation to be dewatered while protecting the containers from moving vehicles and equipment.

**13-4.03E(1): Water Control and Conservation/CASQA Water Conservation Practices (BMP NS-1 and NS-2)**

**13-4.03E(3): Vehicle and Equipment Cleaning/CASQA Vehicle and Equipment Cleaning (BMP NS-8)**

**13-4.03E (4): Vehicle and Equipment Fueling and Maintenance/CASQA Vehicle and Equipment Fueling (BMP NS-9), and CASQA Vehicle and Equipment Maintenance (BMP NS-10)**

**13-4.03E (7): Paving, Sealing, Saw cutting, Grooving, and Grinding Activities:** As listed in Part 9, sections 4 and 5 of the Storm Water Permit, the following additional BMPs shall be implemented for street paving, repaving, reconstruction, patching, dig outs or resurfacing.

1. Restrict paving and repaving activity to exclude periods of rainfall or predicted rainfall unless required by emergency conditions;
2. Install BMPs at all susceptible storm drain inlets and manholes to prevent paving products and tack coat from entering;
3. Prevent the discharge of release agents including soybean oil, other oils, or diesel to the storm water drainage system or watercourses;
4. Minimize non-storm water runoff from water use for the roller and for evaporative cooling of the asphalt;
5. Clean equipment over absorbent pads, drip pans, plastic sheeting or other material to capture all spillage and dispose of properly
6. Collect liquid waste in a container, with a secure lid, for transport to a maintenance facility to be reused, recycled, or disposed of properly **13-4.03D (5)**;
7. Collect solid waste by shoveling and vacuuming or sweeping and securing in an appropriate container for transport to a maintenance facility to be reused, recycled, or disposed of properly **13-4.03D (5)**;
8. Cover "cold-mix" asphalt (i.e., pre-mixed aggregate and asphalt binder) with protective sheeting during a rainstorm **13-4.03C (3)**;
9. Cover loads with tarp before haul-off to a storage site, ensuring that trucks are not overloaded;
10. Minimize airborne dust by using water spray during grinding **14-9.03**;
11. Protect stockpiles with a cover or sediment barriers during a rain event and;
12. Avoid stockpiling soil, sand, sediment, asphalt material and asphalt grindings materials or rubble in or near storm water drainage system or watercourses **13-4.03C (1)**,

**13-4.03F: Sweeping/CASQA Street Sweeping and Vacuuming (BMP SE-7)**

**13-4.04 Payment: Job Site Management** shall be included in the contract lump sum price for Water Pollution Control.

**13-6 Temporary Sediment Control**

**13-6.03C: Temporary Drainage Inlet Protection/CASQA Storm Drain Inlet Protection (BMP SE-10)**

**13-6.04: Payment: Temporary Sediment Control** shall be included in the contract lump sum price for Water Pollution Control Plan. You pay all maintenance costs.

**13-7 Temporary Tracking Control**

**13-7.01A: Temporary Tracking Control/Stabilized Construction Entrance and Exit (BMP TC-1), Entrance Outlet Tire Wash (BMP TC-3)**

**13-7.03 Construction/CASQA Stabilized Construction Site Entrance / Exit (BMP TC-1)**

**13-7.04 Payment: Temporary Tracking Control** shall be included in the contract lump sum price for Water Pollution Control. You pay all maintenance costs.

## 14 ENVIRONMENTAL STEWARDSHIP

### **14-9.03 Dust Control**

**14-9.03A General:** Sweeping per section 14-9.03C shall also be performed to prevent and alleviate dust.

Sweeping, covering stockpiles, applying water, and/or dust palliative, to control dust caused by public traffic is not change order work.

**14-9.03C Construction:** All dust-producing work and unpaved construction sites shall require a minimum watering in the middle and ending of each workday. The frequency of watering shall increase if dust is airborne. Watering shall not produce runoff.

You shall maintain dust control to the satisfaction of the Engineer, 7 days a week, 24 hours per day.

At the end of each work day you shall thoroughly sweep all streets in the work zone to minimize airborne dust.

At the end of each work week you shall sweep all streets in the work zone with a commercial street sweeping truck equipped with a rear pick up broom.

At the Engineer's discretion additional sweeping or watering may be required, including the use of a commercial street sweeping truck equipped with a rear pick up broom, at any time or place.

**14-9.03D Payment:** Full compensation for conforming to this section shall be considered as included in the prices paid for the various contract items of work and no additional compensation will be allowed.

**14-10.01 General:** You shall dispose of all portland cement concrete and asphalt concrete, generated from removal or demolition activities on the project, at a recycler for these materials. You shall provide receipts verifying delivery and approximate quantity (in tons) of the material delivered to a material recycler.

All other excess materials from the project shall become your property and shall be disposed of, at your expense.

**14-10.02A(1) Submittals:** Submit a Solid Waste Disposal and Recycling Report prior to final acceptance of work performed under the Contract. Show the types and amounts of project-generated solid waste taken to or diverted from landfills or reused on the project.

**14-10.02D Payment:** Full compensation for material recycling as specified herein shall be considered as included in the contract prices paid for various items of work, and no additional compensation will be allowed therefor.



## 15 EXISTING FACILITIES

**15-1.03A General:** Existing facilities disturbed by construction shall conform to the applicable provisions of Section 5-1.36. All existing active utilities found to reside in excavated areas shall be supported or protected in place with service maintained during construction. You shall be responsible for any damage caused by your operations and any needed repairs shall be completed to the Engineer's satisfaction.

**15-1.04 Payment:** Full compensation for the protection of existing utilities and their appurtenances is considered as included in the contract prices paid for various contract items of work and no additional allowance will be made therefor.

**15-2.02C Remove Existing Traffic Stripes and Pavement Markings:** Existing thermoplastic pavement markings shall be removed to the fullest extent possible from the pavement by grinding. Sand or other material deposited on the pavement as a result of removing pavement markings shall be removed as work progresses. Existing pavement markings may be removed not more than three (3) days prior to the overlay of the street.

You shall provide, install, and maintain temporary reflective pavement marking on the same day as the permanent markings are removed or as directed by the Engineer and maintain these until final markings are in place. All temporary markings shall be removed immediately before final overlay. Temporary striping on all ground surfaces shall be one coat of paint with reflective glass beads. All ground surfaces shall be cleaned, and dust removed prior to applying paint. Attention is directed to Section 84-1.01, "Traffic Stripes and Pavement Markings" of these Special Provisions.

**15-2.02D Remove Existing Pavement Markers:** Existing pavement markers shall be removed prior to the overlay of the existing road surface. The Contractor shall be responsible for their proper disposal away from the work site. Existing pavement markers may be removed not more than three (3) days prior to the overlay of the street.

You shall provide, install, and maintain temporary reflective pavement markers on the same day as the permanent markers are removed or as directed by the Engineer and maintain these until final markers are in place. Attention is directed to Section 85-1.01, "Raised Pavement Markers" of these Special Provisions

**15-2.02E Payment: Removal of Existing Pavement Markings and Markers** and installation of temporary pavement markings and markers described in Section 15-2 above shall be considered as included in the various items of work under Section 85, "Pavement Markers" and shall include full compensation for furnishing all labor, materials, tools, and equipment, and doing all work involved in furnishing permanent and temporary reflective pavement markings and markers complete in place as specified herein and no additional allowance will be made therefor.

**15-2.05 Lower Existing Facilities:** Existing sewer and storm drain manhole frame and covers, water valve boxes, mainline cleanouts and monuments covers that are located in the roadway excavation, roadway repair, or grind areas shall be lowered below subgrade.

Prior to removal of an existing sewer or storm drain manhole frame, a platform shall be constructed in the manhole above the top of the sewer to prevent any dirt or debris from falling into the sewer. The platform shall remain in place until all work on the manhole has been completed and the asphalt concrete has been placed around the manhole. Prior to the removal of the platform from the manhole, all dirt and debris shall be removed.

You shall accurately locate and record the location of existing manholes, water valve boxes, mainline cleanouts, and monument covers to be adjusted to grade and shall furnish the Engineer a copy of said record prior to starting construction.

**You shall coordinate with all 3<sup>rd</sup> party owned facilities so as not to impact the progression and completion of work.**

**15-2.05A Payment: Lower Existing Facilities** shall be paid for at the contract price per **each**, which price shall include full compensation for furnishing all labor, tools, equipment and doing all the work involved in lowering existing facilities, including constructing and removal of asphalt concrete, install and removal of platform, temporary asphalt paving, installing Section 15, "Existing Facilities" and shall include full compensation for furnishing all labor, materials, tools, and equipment, and doing all work involved in lowering existing manhole frames and covers, water valve boxes, mainline cleanouts and monument covers that are located in roadway.

**15-2.08A General:** Reset existing City facility boxes and lids to grade. The City will furnish to you at no cost, new G-4 water valve boxes and sanitary sewer manhole frame and covers to replace existing water valve boxes and sanitary sewer manhole frame and covers that do not comply with current City Standards or that were damaged prior to Contractor's operations.

**15-2.10B Adjust Existing Manhole Frame and Covers to Grade:** Existing manhole frames and covers, shall be adjusted to grade after the final paving course and shall conform to City Standards and these special provisions.

Existing manhole frames and covers, water valve boxes, mainline cleanouts and monument covers that are located in roadway excavation, roadway repair, or grind areas shall be lowered below subgrade and shall be adjusted after final paving to conform to new finish grade.

**15-2.12C Adjust Existing Water Valve Box, Mainline Cleanout and Monument Covers to Grade:** Existing water valve boxes, mainline cleanouts and monument covers, shall be adjusted to grade after the final paving course and shall conform to City Standards.

All facilities on active systems shall always be accessible to City personnel unless otherwise stated in these Special Provisions or approved by the Engineer.

After the placement of any course of asphalt concrete you shall mark all overlaid manholes, water valve boxes, mainline cleanouts and monument covers, whether new or existing, with white paint by the end of that working day.

All new and existing manholes, water valve boxes, mainline cleanouts and monument covers shall be accessible within 48 hours after they are covered.

Final grade adjustments and installation of concrete collars shall be done on the same working day. Final paving around manholes, water valve boxes, mainline cleanouts and monument covers shall be completed the following working day.

All silt and debris shall be removed from finished structures. This shall include all existing silt and debris plus material caused by your operation.

If new or existing water valve riser pipe needs to be extended after paving to conform to City STD-877, you shall use either a slip x slip glued PVC coupling or a transition coupling with shear bands as directed by the Engineer. Upsizing the existing riser pipe to 8-inch will not be required unless otherwise directed by the Engineer. Any added extension must be a minimum of 12 inches. The lower section of riser pipe shall be adjusted to accommodate this requirement.

In the event that you encounter water valve boxes with round lids or sanitary sewer frame and covers with open pick holes which must be adjusted to grade, you shall provide a count to the Engineer a minimum of two days prior to paving to obtain replacements that complies with current City Standards. The City will provide replacements provided you are not required to replace them as part of the contract or due to damage by your operations.

Prior to removal of an existing manhole frame, a platform shall be constructed in the manhole above the top of the sewer to prevent any dirt or debris from falling into the sewer. The platform shall remain in place until all work on the manhole has been completed and the asphalt concrete has been placed around the manhole. Prior to the removal of the platform from the manhole, all dirt and debris shall be removed.

All grade rings shall be set in cement mortar the same day they are placed. All joints shall be smoothly plastered inside and out.

Existing grade rings removed in the adjustment of manhole frames shall become your property and if undamaged and thoroughly cleaned of mortar may be reused in the work. If not so used, they shall be disposed of away from the site of work at the expense of the Contractor.

Manhole frames shall be reinstalled to align directly over the grade rings. Any frames misaligned by more than ½ inch shall be removed and reinstalled.

New and existing monument covers adjusted shall conform to City Standards.

**15-2.13 Payment: Adjust Existing Manhole Frame and Cover to Grade** shall be paid for at the contract unit price **each**, which price shall include full compensation for furnishing all labor, materials, tools and equipment and doing all the work involved in the final adjustment of manholes to grade, including but not limited to: required excavation and backfill; additional grade rings *if required*; furnishing location of manholes to be adjusted to grade; removing and delivering silent night frames and covers to the City MSC; and transporting new frames and covers to job site, as specified herein, and no additional allowance will be made therefor.

**15-2.15 Payment: Adjust Existing Water Valve Box, Mainline Cleanout and Monument Covers to Grade** shall be paid for at the contract unit price **each**, which price shall include full compensation for furnishing all labor, materials, tools and equipment, and

doing all the work involved in the final adjustment of existing valve boxes, mainline cleanouts and monuments to grade, including but not limited to, required excavation and backfill, replacing to current City Standards, coordination, and removing silt and debris, as specified herein, and no additional allowance will be made therefor.

**15-3.03 Construction:** All removed concrete shall become your property and shall be immediately off-hauled. None of the removed concrete shall be dumped or stockpiled on the work site. You shall dispose of all removed concrete at a recycler for this material. Burying of broken concrete within the limits of the project will not be allowed.

All concrete which is to be removed from sidewalk, curb, gutter and driveway areas shall be removed to the nearest score mark or construction joint as directed by the Engineer unless otherwise noted on Project Plans. The edge of existing concrete to remain shall be neat and free of defects. Saw cutting may be required to achieve this.

Reinforcing steel may be encountered in portions of concrete to be removed and no additional allowance will be made for the removal of such steel.

Irrigation facilities may be encountered during concrete removal and replacement. You shall exercise care in this area and repair any damage done by your operations at no additional cost to the City. Landscaping vegetation such as trees, bushes, plants and other surfaces or structures such as a fence post, shall be restored to original condition at no additional cost to the City.

**Third party pull boxes and or city water meter or electrical boxes may be encountered in the curb ramps, care shall be taken as to not damage the existing pull boxes so that they can be adjusted and reinstalled, and no additional allowance will be made there for.**

**15-3.04 Payment:** Payment for saw cutting, removal and disposal of concrete sidewalk, curb and gutter, adjusting pull boxes, water meter boxes, gas test station boxes, landscape repair, fence post repair, irrigation repair, driveway areas shall be included in the contract prices paid for various contract items of work and no additional allowance will be made therefor.

**15-7 Utility Clearances:** You shall pot hole and investigate, confirm and / or determine the exact locations of existing utilities, and verify clearances between existing and proposed utilities at crossings and/or known potential conflicts. You shall determine elevations and alignments of existing utilities at connection points.

*You shall provide all relevant information in writing to the Engineer immediately upon discovery of any conflict. Any delay in notification to the Engineer may delay direction and/or corrective action and a delay claim due to this reason shall not be considered by the City. You shall not proceed with any work that is in conflict until direction is provided by the Engineer and shall redirect crews to other contract work. All the information required to be obtained per this Section and any other information not noted but relative to the project shall be provided to the Engineer on a set of Plans when the investigative effort is complete.*

**15-7.01 Payment: Utility Clearances** shall be paid for at the contract **lump sum** price which price shall include furnishing all labor, materials, tools and equipment, and doing all

the work involved in verifying utility clearances, including but not limited to: potholing to verify potential conflicts, grades and alignments of existing facilities to be connected to; excavation; backfill; notification; and coordination and redirection of crews to other contract work *if required*, as specified herein, and no additional allowance will be made therefor.

**15-8.00 Root Pruning**: All tree roots two inches and greater which are encountered during excavation which cannot be preserved must be pruned by hand. The roots shall be cut clearly past any damage portion with a sharp hand saw to avoid splits. When digging within the drip line of tree's You shall exercise extreme caution to avoid pulling on roots with excavation equipment. Hand dig around all roots greater than one inch in diameter. You shall notify the Engineer when encountering roots within the drip line of trees which are greater than one inch. If the Engineer elects to get direction from an arborist you shall redirect crews to other contract work after safeguarding the area. The workmanship shall be performed to the best general standards in the industry. All precautions shall be taken to ensure the protection of existing adjacent public or private property.

**15-8.01 Payment** : Root Pruning shall be considered as included in the prices paid for the various contract items of work involved including all labor, materials, tools, and equipment, and for doing all the work involved, including pruning and/or root removal, repair of any damage to existing adjacent public or private property caused by root work only and disposal of root work only debris, as specified herein, and no additional allowance will be made therefor.

## 19 EARTHWORK

**19-1 General:** Non-contaminated site: See section 19-2.03B, Surplus Material, of these Technical Specifications.

**19-1.03B(1) Subgrade Stabilization (0.35') :** Any area of the subgrade determined by the Engineer to be unstable shall be removed to the limits marked in the field by the engineer and shall be removed to 0.35' below the subgrade plane. Soil stabilization fabric shall be placed and anchored per manufactures recommendations. (0.35') of AC Base shall be placed and compacted prior to any other operation.

Use of a pavement grinder shall be considered an acceptable method of excavation for areas requiring subgrade stabilization.

Soil Stabilization Fabric shall be installed and anchored per manufacturer's recommendations and shall meet or exceed the following specifications:

Grab Tensile Strength (ASTM D4632)	290 lb.
Mullin Burst Strength (ASTM D3786)	500 psi
Trapezoid Tearing Strength (ASTM D4533)	113 lb.
Modulus (Load at 10% Elongation) (ASTM D4632)	120 lb.
Apparent Opening Size (ASTM D4751)	40-70 sieve
Permittivity (ASTM D4491)	0.05 sec <sup>-1</sup>

Soil stabilization fabric shall be Mirafi 600-X, GeoTex 315ST, Carthage Mills FX-66, TerraTex HD, or approved equivalent.

**19-1.03C Grade Tolerance:** When HMA is to be placed on the grading plane, the grading plane shall not vary more than 0.05' above or below the grade established by the Engineer

**19-1.04 Payment: Subgrade Stabilization (0.35')** shall be paid for at the contract price per **square yard** as measured in the field. Price shall include full compensation for doing all work involved in stabilizing the subgrade as specified herein including labor, materials, tools and equipment, excavation, and no additional allowance will be made therefor.

Payment for furnishing, placing and anchoring the soil stabilization fabric will be paid per Section 19-8.04 of these Special Provisions and no additional allowance will be made therefor.

Payment for furnishing, placing and compacting the AC Base will be paid per Section 39-6 of these Special Provisions and no additional allowance will be made therefor

In the event of an increase or a decrease in the amount of the engineer's estimated quantity of Subgrade Stabilization, such increase or decrease shall not be considered an alteration in excess of the 25 percent of the contract amount of such items under provisions of Section 4-1.05 of the Standard Specifications and no adjustment of the contract price for Subgrade Stabilization will be made.

No additional compensation will be made for excavation and stabilization beyond the limits of the areas marked by the Engineer or for excavation and stabilization of locations other than those marked by the Engineer. Any excavation for subgrade stabilization done by the Contractor to accommodate equipment width beyond the limits of the areas marked by the Engineer shall be at your expense.

The subgrade shall have all loose material removed prior to the placement of soil stabilization fabric.

After placement of soil stabilization fabric, the excavation shall then be filled with asphalt base as defined in Section 39-1.01, "Asphalt Concrete" of these Special Provisions, and as directed by the Engineer to return the excavation to grade after the material is compacted with a minimum 7-ton vibratory roller or approved equal and has obtained a minimum 93% relative compaction. In the situation where a roller is not able to compact the asphalt base as specified, placement and compaction shall be as directed by the Engineer.

Payment for furnishing, placing and compacting the AC Base will be paid per Section 39-6 of these Special Provisions and no additional allowance will be made therefor.

### **19-2 Roadway Excavation**

**19-2.03A General:** Roadway excavation applies to **Sunset Avenue** from Burbank Ave. to McMinn Ave. and **Rose Ave.** from Stony Point Rd. to Burbank Ave. Both sections shall be removed to 0.60' below the existing finish grade at lip of gutter. Soil stabilization fabric shall be placed and anchored per manufacturers specification and 0.35' of asphalt concrete base and 0.25' asphalt concrete surface shall be placed and compacted prior to any other operation.

Prior to beginning Roadway Excavation, you shall contact the Underground Service Alert at 1-800-227-2600 and provide USA with all necessary data relative to proposed excavation.

Use of a pavement grinder shall be considered an acceptable method of excavation.

**19-2.04 Payment:** **Roadway Excavation** shall be a final pay quantity (**F**) paid for at the contract price per **cubic yard**, which price shall include full compensation for all work as specified herein including excavation, off hauling, dumping, spreading, compacting if required, and no additional allowance will be made therefor.

Removal of existing bituminous pavement and base materials will be paid for as roadway excavation.

Payment for furnishing, placing and anchoring the Soil Stabilization Fabric will be paid per Section 19-8.04 of these Special Provisions and no additional allowance will be made therefor.

Payment for furnishing and placing the asphalt concrete base will be paid per Section 39-6 of these Special Provisions and no additional allowance will be made therefor.

## **19-8 Subgrade Enhancement Geotextile**

**19-8.02 Materials:** Soil stabilization fabric shall be installed and anchored per manufacturer's recommendations and shall meet or exceed the following specifications:

Grab Tensile Strength (ASTM D4632)	290 lb.
Mullin Burst Strength (ASTM D3786)	500 psi
Trapezoid Tearing Strength (ASTM D4533)	113 lb.
Modulus (Load at 10% Elongation) (ASTM D4632)	120 lb.
Apparent Opening Size (ASTM D4751)	40-70 sieve
Permittivity (ASTM D4491)	0.05 sec <sup>-1</sup>

Soil stabilization fabric shall be Mirafi 600-X, GeoTex 315ST, Carthage Mills FX-66, TerraTex HD, or approved equivalent.

**19-8.04 Payment: Soil Stabilization Fabric** shall be paid for at the contract price per **square yard** as measured in the field. Payment shall include full compensation for doing all work involved in placing the fabric including, materials, tools and equipment, and no additional allowance will be made therefor.

## **19-9 Shoulder Backing**

**19-9.02 Materials:** Materials shall be Class II aggregate base as per Section 26 and shall not contain reclaimed asphalt concrete.

**19-9.03 Construction:** Shoulder backing shall be placed adjacent to the newly placed asphalt concrete as shown on the typical plan drawings. The native material to receive the shoulder backing On Rose Ave. shall be removed to a depth of 0.50' x 2' wide. And as directed by the engineer.

**19-9.03 Payment: Shoulder Backing** shall be paid for at the contract price per **ton** in accordance with Section 39-8.02 of the city Specifications. The price shall include full compensation for doing all the work involved in removing and disposing existing base material, spreading and compacting new Class II material, as specified herein including labor, materials tools and equipment, excavation, placement, and no additional allowance will be made therefor.



## 26 AGGREGATE BASE

**26-1.01 Aggregate Base:** Aggregate base shall be Class 2 conforming to and placed in accordance with the requirements of Section 26 of the City Specifications, with the following modifications and additional requirements.

Rolling shall commence immediately after spreading of the damp material and before the material has dried sufficiently to allow separation between the fine and coarse particles.

**26-1.02B Quality Requirements:** The minimum sand equivalent shall be 31 for any individual test.

**26-1.03D Compacting:** The surface of the finished aggregate base shall be firm and unyielding. Any visible movement vertically or horizontally of the aggregate base under the action of construction equipment or other maximum legal axle loads shall be considered as evidence that the aggregate base does not meet this requirement.

**26-1.04 Payment:** Full compensation for Class II aggregate base, except shoulder backing, including supplying, placement and compacting, is considered as included in the prices paid for various items of work and no additional allowance will be made therefor.

## 39 HOT MIX ASPHALT

### **39-1.01 General:**

**39-1.01A Summary:** Section 39 includes technical specifications for producing and placing Hot Mix Asphalt (HMA) by mixing aggregate and asphalt binder at a mixing plant and spreading and compacting the HMA mixture.

A minimum of two weeks prior to the placement of any HMA, you shall notify the Engineer of which asphalt plant will be used to supply the mix. For any job, HMA shall be supplied from a single plant.

Asphalt concrete in areas of subgrade stabilization, roadway excavation and pavement grind areas shall be placed in a manner that does not cause deformation to the ground surface or the adjacent pavement. You shall place asphalt concrete on existing finished grade the same day that an area is ground unless previously approved by the Engineer. Traffic shall not be allowed on ground out roadway surface prior to placement of asphalt.

**39-1.01B Definitions:** For these specifications, HMA and asphalt concrete shall be the same.

At your option, and at no additional expense to the City, a Cal-trans approved Warm Mix Asphalt (WMA) technology may be added to the HMA. However, the asphalt concrete shall be manufactured at HMA temperatures (300F +/- 25F) at a dosage rate approved by the Engineer. All other HMA project specifications shall be adhered to.

Use Section 39-3 Method construction process of these specifications for HMA production and construction.

**39-1.01C Description:** Asphalt concrete shall be placed in separate lifts as shown on the Project Plans.

Roadway excavation and asphalt concrete base paving shall be completed for half the street width before beginning excavation of the remaining street.

All existing asphalt concrete that is adhered to the top of gutters shall be removed in a manner satisfactory to the Engineer and in a manner that does not damage the gutter. Removal shall be prior to placement of new asphalt concrete surface

Asphalt concrete base shall be placed on the same day the area is excavated so that all areas will either have existing asphalt surface or new asphalt concrete base by the end of each working day. No subgrade areas shall be exposed or open to traffic during non-working hours.

Asphalt concrete base paving on Sunset Ave. shall be accomplished by use of a paving machine. The asphalt mix shall be transferred from the haul vehicles to the hopper of the paving machine by means of a shoulder machine equipped with a side caster. Any equipment used to transfer asphalt concrete to the paving machine shall not exceed the

load capacity of any surface it is driven over and shall not produce rutting or pumping of the existing roadway surface or newly placed asphalt concrete base at any time.

Construction vehicles/equipment shall not be allowed on the newly placed asphalt concrete base until the day after it is placed. Super Dumps or other trucks with liftable trailing load bearing axles shall not be allowed on the newly placed asphalt concrete base at any time. All trucks or other construction equipment to be driven on the newly placed asphalt concrete base shall not exceed the surface load bearing capacity and shall not produce rutting, pumping or any deformation at any time.

All longitudinal surface paving joints shall fall on a lane line. Longitudinal subsurface paving joints shall be offset by at least 6 inches.

No longitudinal vertical drop offs will be allowed between the lanes when the roadway is opened to traffic. Where a longitudinal vertical drop off occurs along the roadway crown between the existing street surface and the new asphalt concrete base, you shall grind a 10:1 taper in the existing surface to make a temporary conform to accommodate traffic

Where a vertical drop off will occur between the top of the new asphalt concrete base and a valley gutter, driveway, or side street conform, you shall install a **temporary** 10:1 asphalt taper.

Where a vertical drop off would occur between the asphalt concrete base and a pedestrian ramp, you shall install a temporary 12:1 asphalt taper.

All ground edges adjacent to curb ramps and driveways shall have temporary asphalt concrete ramps (tapers) installed if the asphalt concrete surfacing cannot be placed back the same day the existing pavement is removed. Kraft paper or other bond breaker shall be placed under the conform ramps to facilitate removal when paving operations start. Kraft paper or other bond inhibitor shall be placed under the temporary asphalt taper to facilitate removal when paving operations resume.

Temporary asphalt tapers and associated bond breaker material shall be removed prior to placement of the asphalt concrete surface lift. Where the bond breaker material adheres to the asphalt concrete base course it shall be fully removed with a method, approved by the Engineer that will in no way degrade the quality of the final product.

The asphalt concrete surface lift shall be placed for the full road width of the street each day. No longitudinal cold joints shall be left overnight except as approved by the Engineer.

You shall furnish an excavation and paving plan which shall include the following:

1. Requested location for survey staking of reference points
2. Asphalt plant supplying mix including aggregate source
3. Disposal site for spoils
4. Type of trucks and equipment to be used
5. Haul routes through adjacent residential streets

6. Staging locations

7. Sequencing

You shall set a string line based on the reference points to control the grade of the paving machine along the crown line. A rotary laser level may be used in lieu of a string line provided the level can be accurately set to the design centerline slope, and the detector is directly mounted to the paving machine screed to control the grade of the paving along the crown line. You shall also furnish a grade setter to ensure that the asphalt concrete base and asphalt concrete surface paving conforms to the lines and grades established by the Engineer.

A non-tracking asphalt tack coat shall be applied to all asphalt concrete surfaces and allowed to break in advance of placing all lifts of asphalt concrete. Unless otherwise shown on the Plans, tack coat shall also be applied to all vertical mating surfaces and conforms to existing pavement, curbs, gutters, and construction joints, and allowed to break immediately in advance of placing all lifts of asphalt concrete. The tack coat shall be reapplied 1) where it becomes contaminated, and 2) where it is significantly tracked (removed) from the surface.

The asphalt concrete base and asphalt concrete surface courses shall be allowed to cool to 160° F at mid-depth before the roadway is opened to traffic each day.

At the end of each working day you shall place retro reflectorized signs and delineators, as required for night time use in accordance with the Standard Specifications and Section 12 of these Special Provisions to warn the public of the existing conditions.

At the end of each work day during paving operations the location of all valves, manholes, monuments and any other facility overlaid with asphalt concrete and required to be raised to grade shall be marked in white paint.

**Conform Grind:** shall be in accordance with City Std-208. The width shall be 25', measured parallel to the curb and shall be (0.25') at the conform. Conform Grinds shall be made at side streets and the beginning and ending of these road segments. Or as directed by the Engineer

**Driveway Conform:** shall be (0.25') in depth, asphalt concrete shall be installed and constructed in conformance with City Std's and as directed by the engineer.

**39-1.02 Materials:**

**39-1.02B Tack Coat:** Tack coat shall be a non-tracking hot asphalt product applied to all existing asphalt concrete surfaces to receive an asphalt concrete overlay. Tack coat shall be applied hot at elevated temperature, with a recommended minimum application temperature of 325 degrees Fahrenheit. The non-tracking hot asphalt product shall meet or exceed the following requirements:

<b>Test on Original Asphalt</b>	<b>Test Method</b>	<b>Specifications</b>
Viscosity, @ 329°F, Pa.S	AASHTO T316	3.0 max
Viscosity, @ 347°F, Pa.S	AASHTO T316	0.5 max
Penetration @ 25°C, 100g, 5-sec, dmm	AASHTO T49	6 - 20
Solubility in TCE, % min	AASHTO T44	97.5 min
Flash Point, C.O.C., °F	AASHTO T48	446 min
Softening Point, °F	AASHTO T48	160 min
Tire Rubber Content*, wt. %		1 - 5

\*Tire rubber used shall be 100% soluble in the hot asphalt.

Tack coat shall be applied to all HMA and concrete surfaces. Tack coat shall also be applied to all vertical mating surfaces and conforms to existing pavement, curbs, gutters, and construction joints. The tack coat shall be reapplied 1) where it becomes contaminated, 2) where it is significantly tracked (removed) from the surface, and/or 3) as otherwise directed by the Engineer.

**39-1.02C Asphalt Binder:** Asphalt binder in HMA must comply with the specifications for asphalts.

Asphalt binder to be mixed with aggregate for asphalt concrete surface, leveling and base shall be PG64-16 grade paving asphalt.

The amount of asphalt binder to be mixed with the aggregate shall be specified by the Engineer at the time of paving. Different asphalt binder content may be specified for each lift and each location.

Liquid anti-stripping agent (LAS) shall be added to the asphalt binder at a rate of 0.5 to 1.0% by weight of asphalt binder. The LAS shall be AD-here LOF 65-00 or equivalent, and shall be stored, measured, and blended with the asphalt binder in accordance with the anti-stripping agent manufacturer's recommended practice. The LAS can be added at the asphalt plant or at the refinery. When added at the asphalt plant, the equipment shall indicate and record the amount of LAS added. If added at the refinery, the shipping ticket from the refinery shall certify the type and amount of LAS added.

**39-1.02E Aggregate:** The aggregate grading of the various types of asphalt concrete shall conform to one of the following as directed by the Engineer:

Surface or Leveling Course..... ½-inch Coarse HMA Type A, or ½-inch Medium HMA Type A

Base Course.....¾-inch HMA Type A

Aggregates should be of high abrasion resistance and durability. Excessively soft and friable aggregates are not allowed.

The specified aggregate gradation must be determined before the addition of asphalt binder and includes supplemental fine aggregate.

The proposed aggregate gradation must be within the TV limits for the specified sieve sizes shown in the following tables:

**Aggregate Gradation  
(Percentage Passing)  
HMA Types A**

3/4-inch HMA Type A

Sieve sizes	TV limits	Allowable tolerance
1"	100	--
3/4"	95–100	TV ± 5
3/8"	65–80	TV ± 5
No. 4	49–54	TV ± 5
No. 8	36–40	TV ± 5
No. 30	18–21	TV ± 5
No. 200	2.0–8.0	--

1/2-inch Coarse HMA Type A

Sieve sizes	TV limits	Allowable tolerance
3/4"	100	—
1/2"	94–100	--
3/8"	70–90	--
No. 4	55–61	TV ± 5
No. 8	40–45	TV ± 5
No. 30	20–25	TV ± 5
No. 200	2.0–8.0	--

1/2-inch Medium HMA Type A

Sieve sizes	TV limits	Allowable tolerance
3/4"	100	--
1/2"	95-100	--
3/8"	80-95	--
No. 4	59-66	TV ± 5
No. 8	43-49	TV ± 5
No. 30	22-27	TV ± 5
No. 200	2.0–8.0	--

Before the addition of asphalt binder, the aggregate must have the values for the quality characteristics shown in the following table:

Quality characteristic	Test method	HMA Type A
Percent of crushed particles Coarse aggregate (% min.) One fractured face Two fractured faces Fine aggregate (% min) (Passing no. 4 sieve and retained on no. 8 sieve.) One fractured face	California Test 205	90 75  70
Los Angeles Rattler (% max.) Loss at 100 rev. Loss at 500 rev.	California Test 211	10 45
Sand Equivalent (min.) <sup>a</sup>	California Test 217	50 <sup>b</sup>
Fine aggregate angularity (% min.)	California Test 234	45
Flat and elongated particles (% max. by weight @ 5:1)	California Test 235	10

<sup>a</sup> Reported value must be the average of 3 tests from a single sample.

<sup>m</sup> minimum Sand Equivalent of 45 for asphalt concrete base.

**39-1.02F Reclaimed Asphalt Pavement:** Reclaimed Asphalt Pavement (RAP) may be used at our option. If RAP is used, you shall provide the proposed mix design and the quality control for all HMA that includes RAP, in accordance with the following requirements:

1. You shall provide City with a mix design per California Test 384 for the proposed RAP HMA.
2. As part of City's evaluation of RAP HMA, You and City shall perform bitumen ratio tests on at least six split samples of your RAP to establish correlation between respective binder ignition ovens.
3. RAP shall be processed from reclaimed Asphalt Concrete pavement only.
4. RAP pile(s) shall be separate from the stacker pile, not intermingled with other materials, and stored on smooth surfaces free from debris and organic material.
5. The project RAP pile shall be processed and mixed, identified, and of adequate quantity for the proposed project. "Live" piles shall not be permitted.
6. You shall sample the RAP pile and determine the bitumen ratio (using same binder ignition oven used in #2 above) and provide the test results to the City at least one week prior to producing RAP HMA.
7. A minimum of three samples shall be tested for bitumen ratio for RAP pile of 1500 tons, or portion thereof.
8. RAP pile shall be mixed such that individual bitumen ratio test results of RAP pile so not vary more than +/- 0.5%.
9. During RAP HMA production, RAP shall be sampled by you off of the belt (into the batch plant), per method established by the City, and samples provided to the City.
10. Bitumen ratio of RAP sampled off of the belt shall be 4.0% minimum, as determined by City binder ignition oven. City shall select binder content for RAP HMA mix per Specifications.

11. RAP content shall be no more than 20% by dry aggregate mass in the HMA. If proposing a change in the RAP content, You shall notify the Engineer. If the content changes more than 5%, you shall submit a new mix design.
12. Moisture content of RAP pile shall be 4.0% maximum and shall be tested the day prior to the day of paving and tested/monitored during each day of HMA production.
13. RAP pile(s) shall be protected from exposure to moisture.
14. RAP HMA shall comply with all the specifications for HMA.
15. If batch mixing is used, RAP shall be kept separate from the virgin aggregate until both ingredients enter the weigh hopper or pugmill. After introduction to the pugmill and before asphalt binder is added, the mixing time for the virgin aggregate and RAP shall not be less than five seconds. After asphalt binder is added, the mixing time shall not be less than 30 seconds.
16. If continuous mixing is used, the RAP shall be protected from direct contact with the burner flame with a device such as a shield, separator, or second drum.
17. If any of the above criteria are not satisfied, or if the RAP HMA test result determined by the City are inconsistent, RAP HMA production shall stop for City projects until the issue(s) are corrected.

**39-1.03 HOT MIX ASPHALT MIX DESIGN REQUIREMENTS:**

**39-1.03E Job Mix Formula Verification:**

**(Not Applicable)**

**39-1.08 Production:**

**39-1.08A General:** During production, with approval of the Engineer, you may adjust hot or cold feed proportion controls for virgin aggregate and RAP.

**39-1.12 Smoothness:**

**39-1.12A General:** Determine HMA smoothness with a straightedge. The completed surfacing shall be thoroughly compacted, smooth and free from ruts, humps, depressions or irregularities. Any ridges, indentations or other objectionable marks left in the surface of the asphalt concrete by blading or other equipment shall be eliminated by rolling or other means. The use of any equipment that leaves ridges, indentations or other objectionable marks in the asphalt concrete shall be discontinued, and acceptable equipment shall be furnished by you.

**39-3.02A Testing:** The acceptance testing requirement for Sand Equivalent shall be 50 (minimum) for asphalt concrete surface and 45 (minimum) for asphalt concrete base. HMA shall meet the following requirements.

Aggregate Micro-Deval (ASTM D6928-10) <sup>1</sup>	Tensile Strength Ratio, TSR (ASTM D7870) <sup>2</sup>
≤16.0%	Not Required
16.1-18.0%	70 (minimum)
18.1-21.0%	80 (minimum)



<sup>1</sup> Asphalt concrete with an aggregate Micro-Deval loss greater than 21.0% shall be removed and replaced at your expense. In addition, no single source of asphalt concrete aggregate shall have a Micro-Deval loss greater than 21.0%.

<sup>2</sup> TSR testing shall be performed on re-compacted asphalt concrete (per ASTM D7870), obtained from field cores, and tested within 30 days of asphalt concrete placement. Specimens tested shall include 1 unconditioned sample, and 2 conditioned samples as follows:

- a) 20.0-hour Adhesion cycle @ 60°C
- b) 3500 cycles @ 40 psi and 60°C

A single TSR test shall not represent more than 750 tons of asphalt concrete. Asphalt concrete not meeting the above requirements shall be removed and replaced at your expense.

**39-3.04 Transporting, Spreading, and Compacting:** No asphalt concrete shall be placed within thirty (30) minutes of sunset, as established by weather bureau, except as otherwise authorized by the Engineer.

HMA surface and base shall not be placed during rainy weather or on a wet surface. HMA shall not be placed when the atmospheric temperature is below fifty (50) degrees Fahrenheit or conditions indicate it will drop below fifty (50) degrees Fahrenheit before the material can be satisfactorily compacted. HMA base shall not be placed when the atmospheric temperature is below forty (40) degrees Fahrenheit or conditions indicate it will drop below forty (40) degrees Fahrenheit before the material can be satisfactorily compacted.

The compacted thickness of asphalt concrete layers shall be as directed by the Engineer. The normal minimum and maximum compacted lift thickness for HMA surfacing are 0.17' to 0.25' respectively. The normal minimum and maximum compacted lift thickness for HMA base are .025' to 0.50' respectively.

The temperature of the HMA shall be specified by the Engineer. Unless lower temperatures are specified by the Engineer, all mixtures shall be spread, and the first coverage of initial or breakdown compaction shall be performed, when the temperature of the mixture is not less than 250°F at mid-depth, and all breakdown compaction shall be completed before the temperature of the mixture drops below 200°F at mid-depth. Additional rolling equipment shall be required, or the rate of spread shall be reduced to permit compliance with this requirement

Test sections shall be approved based on the attainment of 93% relative compaction and a satisfactory surface condition following final rolling. The number of coverages required shall be the minimum number required to obtain 93% relative compaction. Relative density shall be the ratio of in-place density (ASTM Test Method D2950) to test maximum density (California Test 309, Method of Test for Determining Theoretical Maximum Specific Gravity and Density of Hot Mix Asphalt) determined during production paving.

The HMA may be cored during paving of the test sections, and the in-place density for each test section shall be the average of three core densities determined per California Test 308.

**39-6 Payment: Asphalt Concrete Surface** shall be paid for at the contract price per **ton**, which price shall include full compensation for furnishing all labor, materials, tools, and equipment and doing all work involved in placing asphalt concrete surface and overlay, including tack coat, and no additional allowance will be made therefor.

**Asphalt Concrete Base** shall be paid for at the contract price per **ton**, which price shall include full compensation for furnishing all labor, materials, tools, and equipment and doing all work involved in placing asphalt concrete base, including tack coat and temporary tapers, and no additional allowance will be made therefor.

**Conform Grind** shall be paid for at the contract price per **linear foot**, which price shall include full compensation for furnishing all labor, materials, tools, and equipment and doing all work involved in conform grinding, including but not limited to drop-offs and tapers, as specified herein, and no additional allowance will be made therefor.

**Driveway Conform (0.25')** shall be paid for at the contract price per **square yard**, which price shall include full compensation for furnishing all labor, materials, tools, and equipment and doing all work involved in placing asphalt concrete driveway conform, including tack coat, minor grading, compaction, grinding, and temporary tapers, and no additional allowance will be made therefor.

Full compensation for installing and removing temporary asphalt tapers shall be included in the contract price for asphalt concrete surface and no additional allowance will be made therefor.

Full compensation for removing existing asphalt concrete from top of gutters shall be included in the contract price for asphalt concrete surface and no additional allowance will be made therefor.

Full compensation for furnishing weigh master's certificates shall be considered as included in the contract price paid per ton for asphalt concrete and asphalt concrete base and no additional allowance will be made therefor.

Sunset Avenue - Burbank Ave. to McMinn Ave.

Rose Ave - Stony Point Rd to Burbank Ave.

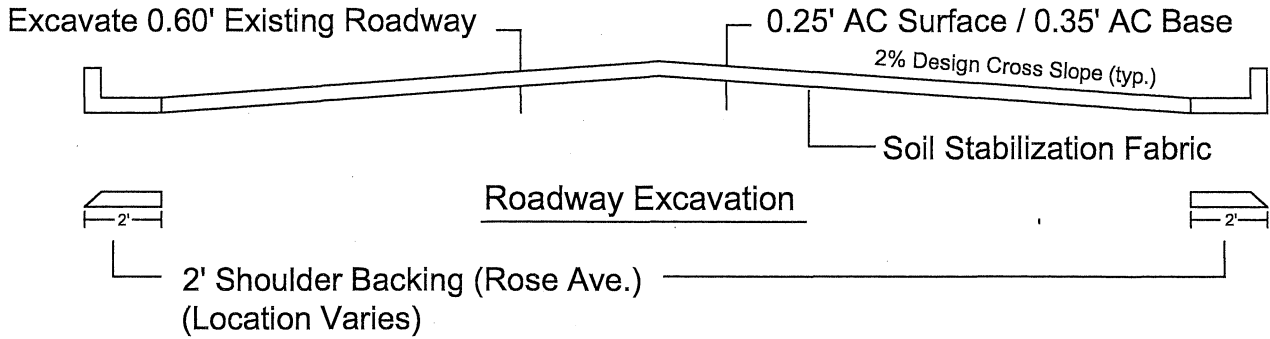

## Typical Street Sections

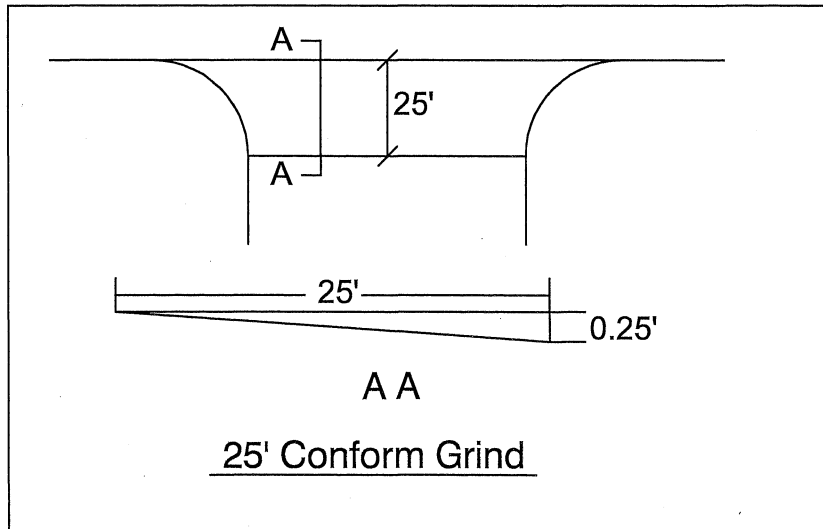

## 25' Conform Grind

Roseland Pavement Maintenance  
Contract Number CO2113

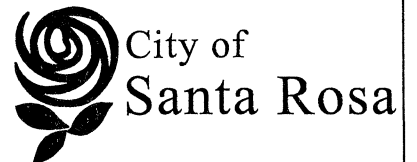

This table describes the location and limits of the proposed improvements:

No.	Street Name	From	To	Length (FT)	No. Of Curb Ramps
1	Sunset Ave.	Burbank Ave.	McMinn Ave.	865	2
2	Rose Ave	Stony Point Rd.	Burbank Ave.	1635	2

This reference table does not show the priority of improvement and / or order of operation.

## 56 SIGNS

**56-2.01 Description:** This work shall consist of removing the existing wooden posts, concrete foundation and metal sign. It shall be replaced with a 2" metal pole imbedded in concrete and existing signs shall be salvaged and mounted on new metal poles.

Where existing signs are located within the new curb ramp area you shall remove and replace signs per city standards and as directed by the engineer.

Full compensation for reinstalling an existing sign shall be considered as included in the price paid for in the various contract items of work involved and no additional allowance will be made there for.

**56-2.06 Payment: Remove And Replace Sign and Post** shall be paid for at the contract price **each**, which price shall include full compensation for furnishing all labor, materials, tools and equipment and doing all work involved in relocating signs, including providing and installing sign hardware, providing and installing new threaded on both ends 2-inch sign pole, coupling & post extension (as needed), and concrete foundation, complete as specified herein, including excavating, coring sidewalk (as needed), backfill, concrete, and replacing landscaping, and no additional allowance will be made therefor.

## 73 CONCRETE CURBS AND SIDEWALKS

**73-1.01A Summary:** This work shall consist of curb and gutter, sidewalks, curb ramp, and valley gutter and shall be constructed at the location detailed in these Special Provisions and in conformance to the requirements of California Building Codes 11B-406.2, 11B-406.3 and 11B-406.5

**73-1.01E Color:** A colored pigment designed for the integral coloring of concrete shall be added to the concrete mix. The pigment shall contain pure concentrated mineral pigments specifically processed for mixing into concrete and complying with ASTM C979. The colored pigment shall be Davis Colors color #860, applied in a dosage of 2 pounds per cubic yard of concrete for a 6 sack mix, or L. M. Scofield color #SG860 applied in a dosage to produce an equivalent color, or an approved equal.

**73-2.03 Construction:** Curb Ramp construction shall be in accordance with Section 73-1.05 of the City Standards and shall be constructed at the location detailed in these Special Provisions.

Curb and Gutter shall be constructed in conformance to City STD-241 of the City Standards and shall be constructed at the location detailed in these Special Provisions.

Sidewalk shall be constructed in conformance to City STD-237 of the City Standards and shall be constructed at the location detailed in these Special Provisions.

All concrete which is to be removed from curb and, gutter areas shall be removed to the nearest construction joint or as directed by the Engineer.

Curb and gutter and sidewalk shall be cured in accordance with the requirements of Section 90-7 of the Standard Specifications except that the Contractor may substitute other than a pigmented sealer upon the approval in writing of such substituted sealer by the Engineer.

Curb Ramp shall be constructed at the locations detailed in these special provisions, per California Building Codes 11B-406.2, 11B-406.3 and 11B-406.5 except the thickness shall be 4" minimum. For purposes of payment, sidewalk, behind sidewalk curb, and detectable warning surface will be included in the square foot cost for Curb Ramp.

Curb Ramp detectable warning surface shall consist of raised truncated domes in accordance with the applicable provisions of section 73 of the City Specifications and these Special Provisions. The detectable warning surface shall be Armor-Tile cast-in-place and surface applied detectable warning surface or approved equal. The color of the detectable warning surface shall be **Yellow**. Detectable warning surface shall be included in the price for curb ramp

All concrete to be removed from the existing retaining curb shall be removed to the nearest vertical joint or as directed by the Engineer. Reinforcing steel may be encountered in the existing retaining curb to be removed and no additional allowance will be made for the removal of such steel.

The detectable warning surface tiles shall be protected from concrete spatter while installing the cast-in-place detectable warning surface into the PCC sidewalk by a temporary 4 mil plastic sheeting or approved equal.

The finished surfaces of the detectable warning surface shall be free from blemishes. No cutting of the tiles shall be allowed. Installation will be per manufacturer's instructions or as directed by the engineer.

The manufacturer shall provide a written 5-year warranty for prefabricated detectable warning surfaces, guaranteeing replacement when there is a defect in the dome shape, color fastness, sound-on-cane acoustic quality, resilience, or attachment. The warranty period shall begin upon acceptance of the contract.

Curb Ramp locations are described in the table at the end of Section 73 of these Special Provisions. You are responsible to correctly interpret the CBC Codes and construct each curb ramp per specified type.

All oil, paint, tire marks, and other discoloring shall be removed from the curb, curb and gutter and sidewalk by sandblasting prior to acceptance by the Engineer. Cement mortar will not be an acceptable substitute for sandblasting. Vandalism to uncured concrete surface shall be removed. If it cannot be removed from the surface, then the vandalized concrete shall be removed and replaced to the nearest score mark.

**73-3.03 Curb and Gutter, Sidewalk, Curb Ramp Construction:** Curb and gutter, sidewalk, curb ramp shall be constructed in accordance with the details and at the location shown on the plans and in conformance to the requirements of Section 73 of the City Specifications with the following modifications and additional requirements.

All concrete which is to be removed from curb and gutter, sidewalk areas shall be removed to the nearest transverse score mark across the full width of sidewalk or construction joint as directed by the Engineer.

Soft or spongy material shall be removed and replaced with suitable material as required by the Engineer.

Curb and gutter, sidewalk, curb ramp, and shall be cured in accordance with the requirements of Section 90-7 of the Standard Specifications except that the Contractor may substitute other than pigmented sealer upon approval in writing of such substituted sealer by the Engineer.

All oil, paint, tire marks, and other discoloring shall be removed from the Curb and gutter, sidewalk, curb ramp, and by sandblasting prior to acceptance by the Engineer. Cement mortar will not be an acceptable substitute for sandblasting. Vandalism to uncured concrete surface shall be removed. If it cannot be removed from the surface, then the vandalized concrete shall be removed and replaced to the nearest score mark.

**73-3.04 Payment:** Curb and Gutter shall be paid for at the contract price per **linear foot**, which price shall include full compensation for detectable warning surface, furnishing and applying curing materials, furnishing all labor, materials, tools and equipment and doing all the work involved in constructing curb and gutter complete in place as specified, including furnishing and placing expansion joint filler, constructing weakened plane joints, excavating, compaction, and backfilling.

**Sidewalk** shall be paid for at the contract price per **square foot**, which price shall include full compensation for furnishing and applying curing materials, removing discoloring, furnishing all labor, materials, tools and equipment and doing all the work involved in constructing sidewalk complete in place as specified, including furnishing and placing expansion joint filler, constructing weakened plane joints, excavating, compaction, and backfilling.

**Curb Ramp** shall be paid for at the contract price per **square foot**, which price shall include full compensation for furnishing and applying curing materials, removing discoloring, furnishing all labor, materials, tools and equipment including **detectable warning surface**, retaining curb at back of sidewalk, and doing all the work involved in constructing curb ramp complete in place as specified, including, furnishing and placing expansion joint filler, constructing weakened plane joints, excavating, co



This table describes the location and limits of the proposed Improvemnts:

Primary Street  
Sunset Avenue

Cross Street	Quadrant	Type of Curb Ramp (per CBC)	Similar Caltrans Standard Plan
McMinn Avenue	NW	Parallel	B
McMinn Avenue	SW	Parallel	MC

Rose Avenue

Janero Dr.	SE	Parallel	C
Janero Dr.	SW	Parallel	C

This reference table does not show the priority of improvemnts and / or order of work.  
However, all curb ramps & valley gutter shall be completed prior to street reconstruct or overlay.

## 84 TRAFFIC STRIPES AND PAVEMENT MARKINGS

**84-1.01 General:** Attention is directed to Section 12 “Temporary Traffic Control” and Section 15 “Existing Facilities” of these Special Provisions. Traffic stripes and pavement markings shall conform to the applicable provisions of Section 84 of the Standard Specifications, The City Traffic Standards, and these Special Provisions and shall be placed at the locations shown on the Plans.

You shall provide and install temporary retro-reflective pavement markings on the same day as the existing permanent markings are removed or destroyed, or as directed by the Engineer, and maintain them until the new permanent markings are in place.

Temporary striping on all ground surfaces shall be paint (white and/or yellow) with retro-reflective glass beads or an approved equivalent and shall be installed the same day as the existing permanent striping is removed, or as directed by the Engineer. Temporary striping shall be maintained until new permanent striping is in place.

Existing pavement markings, including crosswalks, disturbed by construction activities shall be replaced in their entirety.

All striping to be replaced shall match existing, in kind, unless approved by the Engineer.

You shall remove all existing traffic striping and pavement marking in conflict with proposed improvements as directed by the Engineer and shall be responsible for the proper disposal of their grindings away from site work.

Permanent traffic stripes and pavement markings shall be installed after all iron has been raised for that street section, but no more than five days after final paving for that street section.

Existing stripes and pavement markings to remain, which are damaged by the work shall be replaced at your expense. This includes areas outside the immediate project limits.

Painted curbs which are damaged or replaced as part of the work shall be repainted to match existing conditions.

**84-1.04 Payment: Pavement Markings, 12” Thermoplastic Crosswalk and Limit Lines** shall be paid for at the contract **square foot** price, which price shall include furnishing all thermoplastic and glass beads, thermoplastic pavement marking material and furnishing all equipment, tools, and labor, and doing all the work involved as herein specified, including but not limited to, eradication of existing traffic stripes and pavement markings, surface preparation, replacement of damaged stripes, temporary traffic stripes and pavement markings, all temporary traffic measures, and any other work required to install traffic stripes and pavement markings not specifically enumerated in the City Standards, these Special Provisions or on the Project Plans, and no additional allowance will be made therefor.

## SECTION 85 PAVEMENT MARKERS

**85-1.01 General:** Raised pavement markers shall be placed at the locations shown on the Plans and in accordance with the applicable provisions of Section 85 of the Standard Specifications, these Special Provisions, and the City of Santa Rosa Traffic Standards. Attention is directed to Section 15 “Existing Facilities” of these Special Provisions.

**85-1.02 Materials:** All raised pavement markers (RPMs) shall conform to the most current State Specifications.

**85-1.02B Nonreflective Pavement Markers:** All non-reflective pavement markers shall be ceramic.

**85-1.02C Retroreflective Pavement Markers:** Blue reflective raised pavement markers are to be placed per City STD -857 for each fire hydrant within the construction limits of the project. Where a hydrant, whether existing or new, is located at the corner of two streets, a blue RPM shall be placed in each street.

**85-1.03 Construction:** Existing raised pavement markers to remain, that you damage shall be replaced as determined by the Engineer, at your expense. This includes areas outside the immediate project limits.

The exact locations and limits of raised pavement markers will be determined in the field by the Engineer.

You shall provide, install and maintain temporary markers on the same day that the existing permanent markers are removed, or as directed by the Engineer, and maintain this delineation until new permanent markers are in place. Temporary markers on non-ground surfaces shall be plastic adhesive retroreflective delineators.

Existing raised pavement markers conflicting with the proposed striping shall be removed immediately prior to placement of new markers.

Holes left in the pavement due to the removal of raised pavement markers shall be filled with enough adhesive to replace any asphalt which comes off with the removal of the pavement marker, leaving a level driving surface.

Permanent raised pavement markers shall be installed within 5 days following final pavement operations. Temporary markings shall be in place the same day of pavement operations.

**85-1.04 Payment:** **Pavement Markers, retroreflective and non-reflective**, shall be paid for at the contract unit price **each**, which price shall include full compensation for furnishing all labor, materials, tools and equipment, and doing all work involved in placing raised pavement markers, complete in place, including adhesives, removing existing pavement markers, and no additional allowance will be made therefor.

## 121 NOTIFICATION

**121-1.01:** You shall notify the Engineer of any work to be performed on any given work day either on the afternoon of the prior working day or before 8:30 a.m. on the given working day. Any work completed for which the Engineer has not received prior notification of its scheduling MAY NOT BE ACCEPTED FOR PAYMENT.

**121-3.01 Payment:** Full compensation for conforming to the provisions of this section shall be considered as included in the prices paid for the various contract items of work involved and no additional compensation will be allowed therefor.

## 124 MATERIAL RECYCLING

**124-1.01 Description:** You shall dispose of all portland cement concrete and asphalt concrete, generated from removal or demolition activities on the project, at a recycler for these materials. You shall provide receipts verifying delivery and approximate quantity (in tons) of the material delivered to a material recycler.

All other excess materials from the project shall become your property and shall be disposed of by you, at your expense.

**124-1.02 Payment:** Full compensation for material recycling as specified herein shall be considered as included in the contract prices paid for various items of work, and no additional compensation will be allowed therefor.

BID FORMS

**CITY OF SANTA ROSA**

**STATE OF CALIFORNIA**

ROSELAND PAVEMENT MAINTENANCE

The work to be performed and referred to herein is in the City of Santa Rosa, California and consists of improvements to be constructed in accordance with the provisions of the Invitation for Bids, containing the Notice to Bidders, the Special Provisions, the Project Plan(s), the Bid Forms and the Contract, all of which are by reference incorporated herein, and each Addendum, if any is issued, to any of the above which is also incorporated by reference herein.

TO THE AWARD AUTHORITY OF THE CITY OF SANTA ROSA

The undersigned, as bidder, declares that the only person or parties interested in this bid as principals are those named herein; that this bid is made without collusion with any other person, firm, or corporation; that Contractor has carefully examined the Project Plans, Invitation for Bids and conditions therefor, and is familiar with all bid requirements, that Contractor has examined this Contract and the provisions incorporated by reference herein, and Contractor hereby proposes, and agrees that if its bid is accepted by the City, Contractor will provide all necessary machinery, tools, apparatuses, and other means of construction, and to do all the work and furnish all the materials and services required to complete the construction in accordance with the Contract, the Special Provisions, the Project Plan(s), and Addenda to any of the above as incorporated by reference, in the time stated herein, for the unit prices and/or lump sum prices as follows:

**CITY OF SANTA ROSA  
UNIT PRICE SCHEDULE  
C02113 - ROSELAND PAVEMENT MAINTENANCE**

Bidder Name: \_\_\_\_\_

No.	Item	Quantity	Units	Unit Price	Total Price
1	TRAFFIC CONTROL	1	LS	\$ _____	\$ _____
2	WATER POLLUTION CONTROL	1	LS	\$ _____	\$ _____
3	LOWER EXISTING FACILITIES	17	EA	\$ _____	\$ _____
4	ADJUST EXISTING MANHOLE FRAME AND COVER TO GRADE	6	EA	\$ _____	\$ _____
5	ADJUST EXISTING WATER VALVE BOX, MAINLINE CLEANOUT, AND MONUMENT COVER TO GRADE	11	EA	\$ _____	\$ _____
6	UTILITY CLEARANCES	1	LS	\$ _____	\$ _____
7	ROADWAY EXCAVATION (F)	2450	CY	\$ _____	\$ _____
8	SOIL STABILIZATION FABRIC	7350	SY	\$ _____	\$ _____
9	SHOULDER BACKING	25	TON	\$ _____	\$ _____
10	ASPHALT CONCRETE SURFACE	1450	TON	\$ _____	\$ _____
11	ASPHALT CONCRETE BASE	1950	TON	\$ _____	\$ _____
12	CONFORM GRIND	125	LF	\$ _____	\$ _____
13	DRIVEWAY CONFORM (0.25')	300	SY	\$ _____	\$ _____
14	REMOVE AND REPLACE SIGN AND POST	12	EA	\$ _____	\$ _____
15	CURB AND GUTTER	130	LF	\$ _____	\$ _____
16	SIDEWALK	100	SF	\$ _____	\$ _____
17	CURB RAMP	800	SF	\$ _____	\$ _____
18	PAVEMENT MARKINGS, 12" THERMOPLASTIC CROSSWALK AND LIMIT LINES	175	SF	\$ _____	\$ _____
19	PAVEMENT MARKERS, RETRO-REFLECTIVE AND NON-REFLECTIVE	30	EA	\$ _____	\$ _____
<b>GRAND TOTAL BID</b>					<b>\$ _____</b>

In the case of any discrepancy between the unit price and the total set forth for the item, the unit price shall prevail; provided, however, that if the amount set forth as a unit price is ambiguous, unintelligible or uncertain for any reason, or is omitted, or in the case of lump sum items, is not the same amount as the entry in the "Total" column, then the amount set forth in the "Total" column for the item shall prevail in accordance with the following:

1. As to lump sum items, the amount set forth in the "Total" column shall be the unit price;
2. As to unit basis items, the amount set forth in the "Total" column shall be divided by the estimated quantity for the item and the price thus obtained shall be the unit price.

The Total Base Bid shall be the sum of the "Total" column. In case of discrepancy between the sum of the "Total" column and the amount entered as Total Base Bid, the sum of the "Total" column shall prevail. The bid comparison will be based on the sum of the "Total" column for each bidder.

If this Contract Bid is accepted by the City and the undersigned fails to execute the Contract and to give all the bonds required under the Contract, with a surety satisfactory to the Award Authority of the City of Santa Rosa, within ten calendar days after bidder has received the Notice of Award from the Engineer, then the Award Authority may, at its option, determine that the bidder has abandoned the Contract, and thereupon this bid and the acceptance thereof shall be null and void, and the forfeiture of the security accompanying this bid shall be in accordance with California Public Contract Code section 20172.

The undersigned understands and agrees that the City is not responsible for any error or omissions on the part of the undersigned in making this bid.

The bidder to whom the Contract is awarded agrees to execute the Contract in favor of the City, in the form attached, and to deliver any and all required bond(s) and insurance certificates within ten calendar days from the date of Contractor's receipt of the Notice of Award. Following the award of the Contract, Contractor shall commence work within ten calendar days from the day authorized in the Notice to Proceed and diligently prosecute the same to completion in accordance with Section 8-1.04.



## LIST OF SUBCONTRACTORS

**NAME OF BIDDER:** \_\_\_\_\_

The following is a list of each subcontractor who will perform work or labor or render services to the undersigned for the construction of the project in an amount in excess of ½ of 1% of the total amount of this bid.

The undersigned agrees that any portion of the work in excess of ½ of 1% of the total amount of this bid and for which no subcontractor is designated herein will be performed by the undersigned.

<b>SUBCONTRACTOR NAME</b>	<b>SUBCONTRACTOR LICENSE NUMBER</b>	<b>SUBCONTRACTOR DIR REGISTRATION NUMBER</b>	<b>SUBCONTRACTOR BUSINESS ADDRESS</b>	<b>DESCRIPTION OF WORK (ITEM NO.)</b>



NONCOLLUSION DECLARATION  
TO BE EXECUTED BY BIDDER AND SUBMITTED WITH BID

The undersigned declares:

I am the \_\_\_\_\_ of \_\_\_\_\_, the party making the foregoing bid. The bid is not made in the interest of, or on behalf of, any undisclosed person, partnership, company, association, organization, or corporation. The bid is genuine and not collusive or sham. The bidder has not directly or indirectly induced or solicited any other bidder to put in a false or sham bid. The bidder has not directly or indirectly colluded, conspired, connived, or agreed with any bidder or anyone else to put in a sham bid, or to refrain from bidding. The bidder has not in any manner, directly or indirectly, sought by agreement, communication, or conference with anyone to fix the bid price of the bidder or any other bidder, or to fix any overhead, profit, or cost element of the bid price, or of that of any other bidder. All statements contained in the bid are true. The bidder has not, directly or indirectly, submitted his or her bid price or any breakdown thereof, or the contents thereof, or divulged information or data relative thereto, to any corporation, partnership, company, association, organization, bid depository, or to any member or agent thereof, to effectuate a collusive or sham bid, and has not paid, and will not pay, any person or entity for such purpose.

Any person executing this declaration on behalf of a bidder that is a corporation, partnership, joint venture, limited liability company, limited liability partnership, or any other entity, hereby represents that he or she has full power to execute, and does execute, this declaration on behalf of the bidder.

I declare under penalty of perjury under the laws of the State of California that the foregoing is true and correct and that this declaration is executed on \_\_\_\_\_ [date], at \_\_\_\_\_ [city], \_\_\_\_\_ [state].

NOTE: The above Noncollusion Declaration is part of the Contract Bid. Signing this Bid on the signature portion thereof shall also constitute signature of this Noncollusion Declaration.

BID BOND AFFIDAVIT AND BIDDER'S SIGNATURE PAGE

Accompanying this bid is a guaranty in the form of (Notice: Insert the words "cash \$," "Cashier's Check," "Certified Check," or "Bidder's Bond" as the case may be):

\_\_\_\_\_

in an amount equal to at least ten percent of the total of this bid.

The undersigned further agrees that if Contractor does not execute the Contract and deliver the necessary bonds to the City within the period of time specified in this Invitation for Bids, the proceeds of the security accompanying this bid shall become the property of the City of Santa Rosa, California, and this bid and the acceptance thereof may, at the option of the City, be considered null and void.

The undersigned is licensed in accordance with an act providing for the registration of Contractors, License No. \_\_\_\_\_, Class \_\_\_\_\_, expiration date \_\_\_\_\_.

The undersigned in registered with the Department of Industrial Relations, Registration No. \_\_\_\_\_.

**IMPORTANT NOTICE:** If bidder or other interested person is a corporation, state legal name of corporation, also names of the president, secretary, treasurer, and manager of the corporation; if a partnership, state true name of partnership, also the names of all partners in the partnership; if the bidder is a sole proprietor, state the business name and the proprietor's name in full.

Secretary of State Business Entity Number: \_\_\_\_\_.

\_\_\_\_\_  
\_\_\_\_\_  
\_\_\_\_\_  
\_\_\_\_\_

Business Address

\_\_\_\_\_  
\_\_\_\_\_

Telephone Number

I declare under penalty of perjury that the foregoing is true and correct.

BIDDER'S SIGNATURE: \_\_\_\_\_

TITLE: \_\_\_\_\_

DATE: \_\_\_\_\_

**CONTRACT**

**CITY OF SANTA ROSA**

**CALIFORNIA**

**CONTRACT NO. C02113  
ROSELAND PAVEMENT MAINTENANCE**

This Contract is made and entered into as of date to be added upon award at Santa Rosa, California, between the City of Santa Rosa ("City") and \_\_\_\_\_ of \_\_\_\_\_ ("Contractor").

ARTICLE I - For and in consideration of the payment and agreement hereinafter mentioned, to be made and performed by City, and under the conditions expressed in the required bonds hereunto annexed, Contractor agrees that for the benefit of City, at its own cost and expense, to do all the work and furnish all the materials, except such as are mentioned in the Special Provisions to be furnished by City, necessary to construct and complete the work herein described in a good, workmanlike, and substantial manner. The work embraced herein shall be done in accordance with the Standard Specifications of the State of California Department of Transportation, dated 2010, insofar as the same may apply (Standard Specifications); in accordance with the City of Santa Rosa Construction Specifications for Public Improvements (City Specifications); in accordance with the City of Santa Rosa Design and Construction Standards, (City Standards); in accordance with the State of California Department of Transportation Standard Plans, dated 2010 (Standard Plans), (collectively, "Contract Documents") and in accordance with the Special Provisions hereinabove set forth, all of which are hereby incorporated into and made part of this Contract.

ARTICLE II - Contractor agrees to receive and accept the following prices as full compensation for furnishing all materials and doing all the work contemplated and embraced in this Contract; also for all loss or damages arising out of the nature of the work aforesaid, or from the acts of the elements, or from any unforeseen difficulties or obstructions which may arise or be encountered in the prosecution of the work until its acceptance by City and for all expenses incurred by or in consequence of the suspension or discontinuance of work, and for well and faithfully completing the work, and the whole thereof in the manner and according to the Project Plans and Invitation for Bids therefor, and the requirements of the Engineer under them to wit:

ITEM NUMBER	QUANTITY	DESCRIPTION	UNIT PRICE	TOTAL
			\$ _____	\$ _____
TOTAL BASE BID (SUM OF "TOTAL" COLUMN)			\$ _____	

**BID ITEMS IN THIS SECTION WILL BE INSERTED  
UPON AWARD OF THE CONTRACT AND SHALL BE  
THE SAME AS THOSE BID UPON.**

ARTICLE III - City and Contractor hereby promise and agree that Contractor shall provide the materials and do the work according to the terms and conditions herein contained and referred to, for the prices aforesaid, and City hereby agrees to pay for the same at the time, in the manner, and upon the conditions set forth; and the parties for themselves, their heirs, executors, administrators, successors, and assigns, do hereby agree to full performance of the covenants herein stated.

ARTICLE IV - By execution of this Contract, Contractor hereby represents and certifies that Contractor is aware of the provisions of Labor Code section 3700 which require every employer to be insured against liability for Workers' Compensation or to undertake self-insurance in accordance with the provisions of that Code, and Contractor hereby agrees to comply with such provisions before commencing the performance of the work of this Contract.

ARTICLE V - It is further expressly agreed by and between the parties hereto that the Invitation for Bids, containing the Notice to Bidders including any required Bonds, the Contract Documents, and any Addenda are all essential parts of this Contract and are specially referred to and by such reference made a part hereof. In the event of any conflict in the provisions thereof, the terms of said documents shall control each over the other, in the following order:

1. Special Provisions
2. City Standards
3. City Specifications
4. Standard Specifications
5. Standard Plans

ARTICLE VI - Contractor agrees to commence work pursuant to this Contract within ten calendar days from the date authorized in the Notice to Proceed and to diligently prosecute the same to completion in accordance with Section 8-1.04C of the Special Provisions.

This Contract shall not be transferred or assigned without the prior written consent of City, which may be withheld by City in its sole and absolute discretion.

If Contractor is a corporation, two corporate officers of Contractor, one from each of the following two groups shall execute this Contract: a) the chairman of the board, president or any vice-president; b) the secretary, any assistant secretary, chief financial officer, or any assistant treasurer. The name and title of the corporate officers shall be printed under the signature.

In witness whereof, the parties hereto have executed this Contract as of the date first written above.

**City:**

City of Santa Rosa,  
a Municipal corporation

By: \_\_\_\_\_

Title: \_\_\_\_\_

ATTEST:

By: \_\_\_\_\_

Title: \_\_\_\_\_

Approved as to form:

By: \_\_\_\_\_

Office of City Attorney

**Contractor:**

Name of Contractor,  
Type of entity

By: \_\_\_\_\_

Name: \_\_\_\_\_

Title: \_\_\_\_\_

By: \_\_\_\_\_

Name: \_\_\_\_\_

Title: \_\_\_\_\_